

Gas-fired wall-mounted condensing boiler
 25 to 230 MBH/7 to 67 kW
 Multi-boiler installation 344 to 920 MBH/

Technical Data Manual

Model Nos. and pricing: see Price List



Vitodens 200, WB2-24C/24/32

Vitodens 200, WB2-44/60
 (with preinstalled vent pipe adaptor)

Vitodens 200

WB2 Series

Gas-Fired Wall-Mounted Condensing Boiler
 with modulating Matrix-compact gas burner
 for room air independent operation
 (using a direct vent system and room air
 dependent operation)

For Natural Gas and Liquid Propane
 Heating input NG 25 to 230 MBH
 7 to 67 kW
 Heating input LP 25 to 214 MBH
 7 to 63 kW



Product Information

VITODENS 200

The Vitodens 200 is a high-quality condensing boiler made of stainless steel, developed in accordance with the latest achievements of the condensing boiler technology industry. In terms of energy usage, for example, the Vitodens 200 is uncompromising: Thanks to the innovative condensing technology of the boiler with modulating Matrix-compact gas burner and the especially developed Inox-Radial heat exchanger surface, made of stainless steel, the Vitodens 200 reaches an A.F.U.E. of up to 95.2%.

The benefits at a glance:

- **Highest efficiency** with full modulation up to 98%. A.F.U.E. up to 95.2%.
- **Maximum reliability**
High-alloy stainless steel (SA240 316Ti)
Inox-Radial heat exchanger constructed in compliance with CSA B51 and ASME Section IV.
Maximum pressure rating: 45 psig.
- **Protect the environment**
Extremely low emissions with modulating Matrix-compact gas burner.
NO_x: 8.9 ppm (air-free)
CO: 5.5 ppm (air-free)
- **Compact, lightweight design.**
Zero clearance to combustibles. Limited space is not an issue.
- **Clean, esthetically pleasing appearance** for installation anywhere in your living area.
- **Extremely quiet** operation; quieter than most refrigerators.
- **Smart burner technology**
Factory calibrated, self-adjusting burner.
No adjusting in the field, reduced operating cost.
- **Powerful and user-friendly** outdoor reset control, built-in and prewired with diagnostic system.
Controls multi-temperature space heating and DHW systems.

■ **Reliable DHW production two ways:**

- Combi model features an integrated DHW Quick System. No DHW tank required.
- Unlimited DHW supply with a stand-alone DHW tank with any other Vitodens 200.

■ **Multiple venting options:**

- Horizontal or vertical sealed combustion coaxial vent system (factory supplied)
- Horizontal, vertical or hybrid sealed combustion double-pipe vent system (field supplied)
- Horizontal or vertical single-wall vent system (field supplied)

■ **Multi-boiler installation**

Models WB2-44 and -60 can be combined to a maximum of 4 boilers. **Ideal for light commercial applications.**

■ **One version for all elevation levels**

(0 to 10 000 ft. / 0 to 3048 m).

■ **Fast, simple conversions** to natural or propane gas.

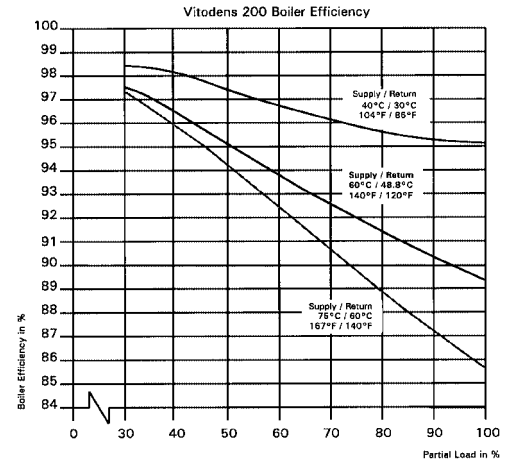

Vitodens 200 –
Models WB2 11-44 and 15-60
172 MBH to 230 MBH/50 kW to 67 kW

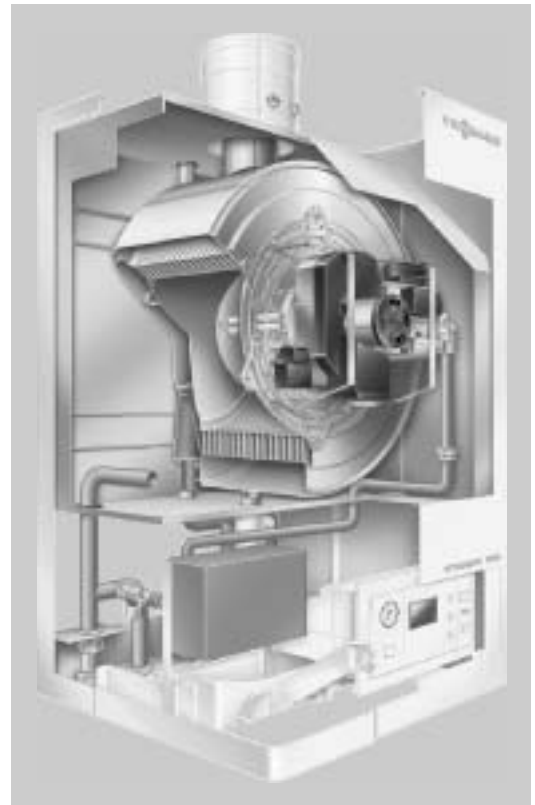

5167 472 v3.4

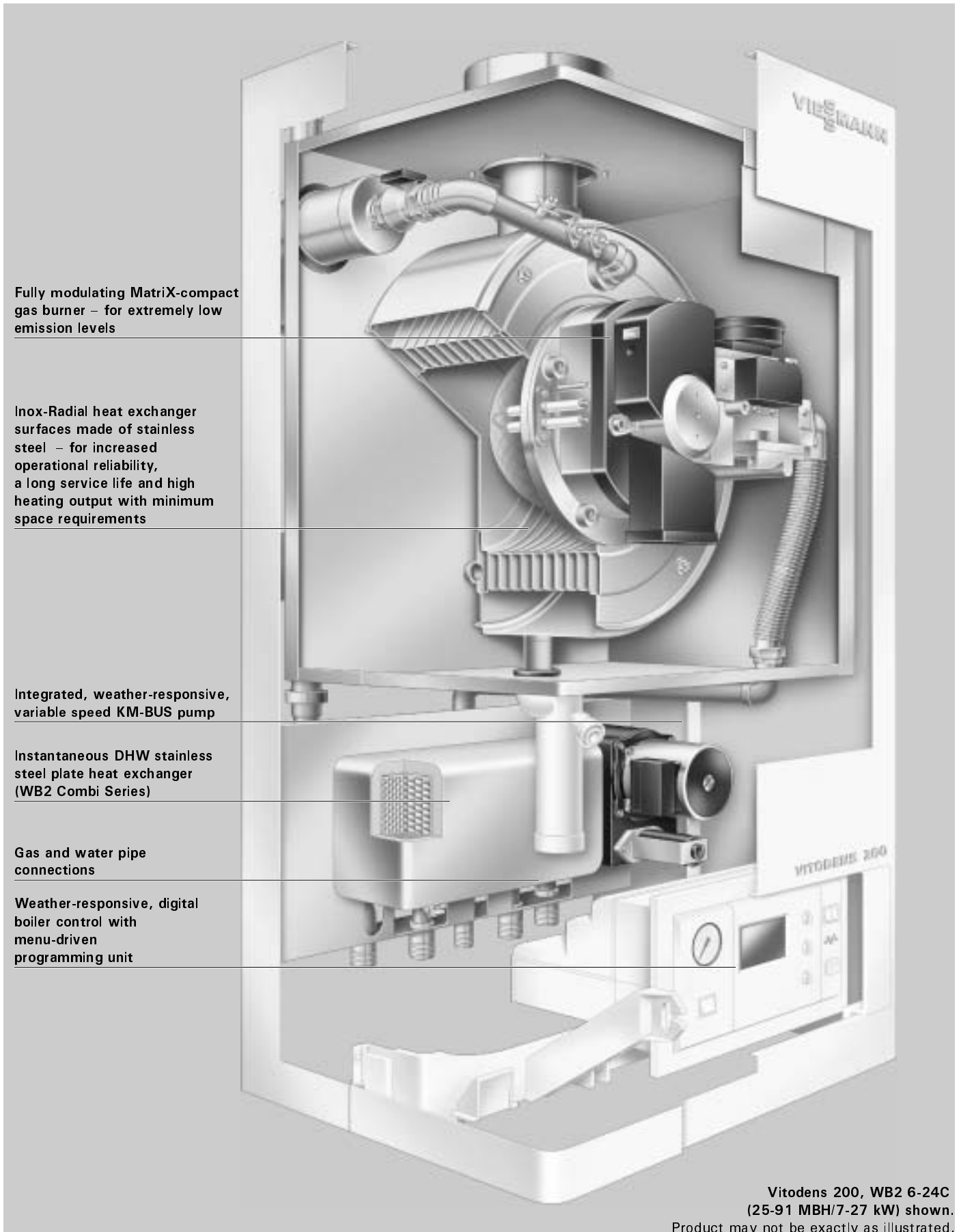

Vitodens 200

Technical Data

		Combi Series			Standard heating boiler		
Boiler Model	Model No.	WB2 6-24C	WB2 6-24	WB2 8-32	WB2 11-44	WB2 15-60	
Natural gas							
CSA input	MBH	25-91	25-91	37-124	55-172	80-230	
	kW	7-27	7-27	11-36	16-50	23-67	
CSA output/DOE ^{*1}	MBH	22-81	22-81	33-112	49-154	71-206	
heating capacity	kW	6-24	6-24	10-32	14-44	21-60	
Net I = B = R rating ^{*2}	MBH	70	70	97	133	178	
Propane gas							
CSA input	MBH	25-81	25-81	37-112	55-155	80-214	
	kW	7-24	7-24	11-33	16-45	23-63	
CSA output/DOE ^{*1}	MBH	22-73	22-73	33-101	49-139	71-192	
heating capacity	kW	6-21	6-21	10-30	14-40	21-56	
Net I = B = R rating ^{*2}	MBH	63	63	88	120	166	
Heat exchanger surface area	ft. ²	8.22	8.22	9.91	20.91	20.91	
	m ²	0.76	0.76	0.92	1.94	1.94	
Min. gas supply pressure							
Natural gas	"w.c.	4	4	4	4	7	
Propane gas	"w.c.	11	11	11	11	11	
Max. gas supply pressure ^{*3}							
Natural gas	"w.c.	14	14	14	14	14	
Propane gas	"w.c.	14	14	14	14	14	
A.F.U.E.	%	95.2	95.2	95.2	95.2	95.2	
Weight	lbs	159	143	165	214	214	
	kg	72	65	75	97	97	
Boiler water content	USG	1.1	1.1	1.2	4.3	4.3	
	ltr	4.0	4.0	4.6	16.45	16.45	
Integrated pump flow rate	GPM	4.6	4.6	4.6	--	--	
at 6.6 ft./2 m head pressure ^{*4}	ltr/h	1050	1050	1050	--	--	
Boiler max. flow rate ^{*5}	GPM	6.2	6.2	7.0	15.4	15.4	
	ltr/h	1400	1400	1600	3500	3500	
Max. operating pressure	psig	45	45	45	45	45	
at 210 °F/99 °C	bar	3	3	3	3	3	
Boiler water temperature							
– Adjustable high limit (AHL) range							
space heating	°F/	68 to 167/					
(steady state)	°C	20 to 75					
DHW production	°F/	108 to 172/					
	°C	42 to 78					
– Fixed high limit (FHL) °F/°C							
210/99							
Boiler connections							
Boiler heating supply and return	NPTM "	¾	¾	¾	1 ¼	1 ¼	
Pressure relief valve	NPTF "	¾	¾	¾	¾	¾	
Drain valve	(male thread)	¾	¾	¾	¾	¾	
Boiler supply/return for indirect-fired DHW storage tank	NPTM "	--	¾	¾	1 ¼	1 ¼	

^{*1}Output based on 140°F / 60°C, 120 °F / 49°C system supply/return temperature.

^{*2}Net I = B = R rating based on piping and pick-up allowance of 1.15.

^{*3}If the gas supply pressure exceeds the maximum gas supply pressure value, a separate gas pressure regulator must be installed upstream of the heating system.

^{*4}With pump rotational speed set to 100% flow capacity (2700 rpm), see Coding Address 045 in the Vitodens 200 Start-up/Service Instructions. Pump factory default setting is 65% flow capacity (2000 rpm).

^{*5}See "Typical System Flow Rates" on page 8 in this manual.

		Combi Series			Standard heating boiler	
Boiler Model	Model No.	WB2 6-24C	WB2 6-24	WB2 8-32	WB2 11-44	WB2 15-60
Dimensions						
Overall depth	inches	16	16	16	21 ½	21 ½
	mm	406	406	406	550	550
Overall width	inches	19 ¾	19 ¾	19 ¾	23 ½	23 ½
	mm	500	500	500	600	600
Overall height	inches	35 ½	35 ½	35 ½	35 ½	35 ½
	mm	900	900	900	900	900
Height with flue gas elbow (accessory)	inches	44	44	44	47 ¼	47 ¼
	mm	1116	1116	1116	1200	1200
Gas supply connection	NPTF "	½	½	½	¾	¾
Standby instantaneous DHW plate heat exchanger of Combi boiler*6						
Water content	DHW side USG/ltr	0.26/1.00	--	--	--	--
	heating water side USG/ltr	0.18/0.70	--	--	--	--
Connections DHW and DCW	NPTF "	½	--	--	--	--
Max. operating pressure (DHW side)*7	psig/bar	150/10	--	--	--	--
DHW supply temp. range	°F/°C	100-135/38-57	--	--	--	--
Continuous draw rate with a temperature increase from 50 to 113 °F/10 to 45 °C	GPH	156	--	--	--	--
	ltr/h	590	--	--	--	--
Draw rate range	GPM	0.8-2.1	--	--	--	--
	ltr/min	3-8	--	--	--	--
Flue gas*8						
Temperature (at boiler return temperature of 86 °F/30 °C)						
- at rated full load	°F/°C	113/45	113/45	113/45	95/35	104/40
- at rated partial load	°F/°C	95/35	95/35	95/35	91/33	95/35
Temperature (at boiler return temperature of 140 °F/60 °C)						
- at rated full load	°F/°C	158/70	158/70	158/70	149/65	158/70
Average condensate flow rate*9						
with natural gas and						
- T _S /T _R = 167/140°F/75/60 °C	USG/day	2-2.6	2-2.6	2.6-3	2.9-4	4.8-5.8
	ltr/day	8-10	8-10	10-12	11-15	18-22
- T _S /T _R = 104/86°F/40/30 °C	USG/day	2.9-3.4	2.9-3.4	4-4.5	3.7-5	6-7.4
	ltr/day	11-13	11-13	15-17	14-19	23-28
Condensate connection*10						
	hose nozzle					
	Ø in	1	1	1	1	1
Boiler flue gas connection*11						
	Ø in/mm	3 ¼/80	3 ¼/80	3 ¼/80	4 ¼/110	4 ¼/110
Combustion air supply connection*11						
	outer Ø in/mm	5/125	5/125	5/125	6/150	6/150

*6 Minimum pressure for domestic cold water connection 1 bar/15 psig.

*7 See DHW sizing chart on page 11 in this manual.

*8 Measured flue gas temperature with a combustion air temperature of 68 °F/20 °C.

*9 Based on typical boiler cycles, including partial load conditions.

*10 Requires 1"/25 mm tubing. See Vitodens 200 Installation Instructions for details.

*11 For side wall vent installations:

Do **not** exceed max. equivalent length of 20 ft./6 m as stated in the Installation Instructions of the Vitodens 200 Venting System. A **maximum of five elbows** may be installed in the vent system.

Do **not** attempt to common-vent Vitodens 200 with any other appliance.

Venting material to be supplied by Viessmann **only**; side wall vent installation **must** include Viessmann protective screen!

For details refer to the venting section starting on page 17 or the Installation Instructions for the Vitodens 200 Venting System.

► For information regarding other Viessmann System Technology componentry, please reference documentation of respective product.

Vitodens 200

Vitodens 200 up to model WB2 8-32

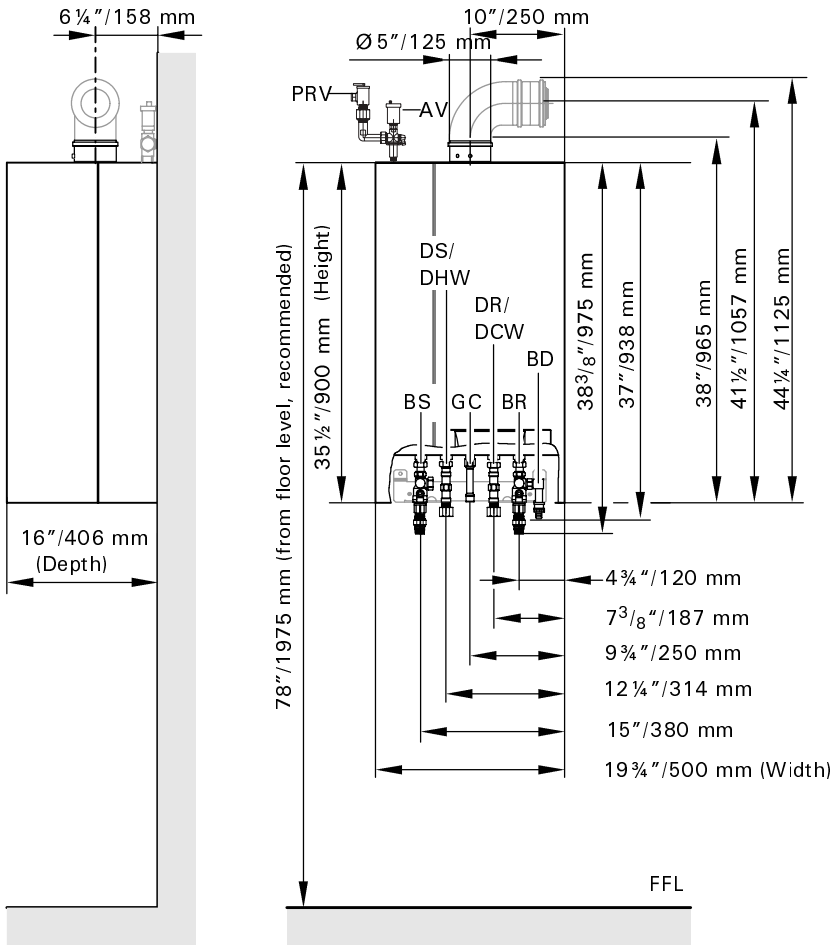

Legend

AV Air Vent
 BD Boiler Drain
 BR Boiler Return
 BS Boiler Supply
 FFL Finished Floor Level
 GC Gas Connection
 PRV Pressure Relief Valve

Only for Combi heating boiler

DCW Domestic Cold Water 1/2"
 DHW Domestic Hot Water 1/2"

Only for standard heating boiler

DR Boiler heating return for domestic hot water production 3/4"
 DS Boiler heating supply for domestic hot water production 3/4"

Vitodens 200 model WB2 11-44 and up

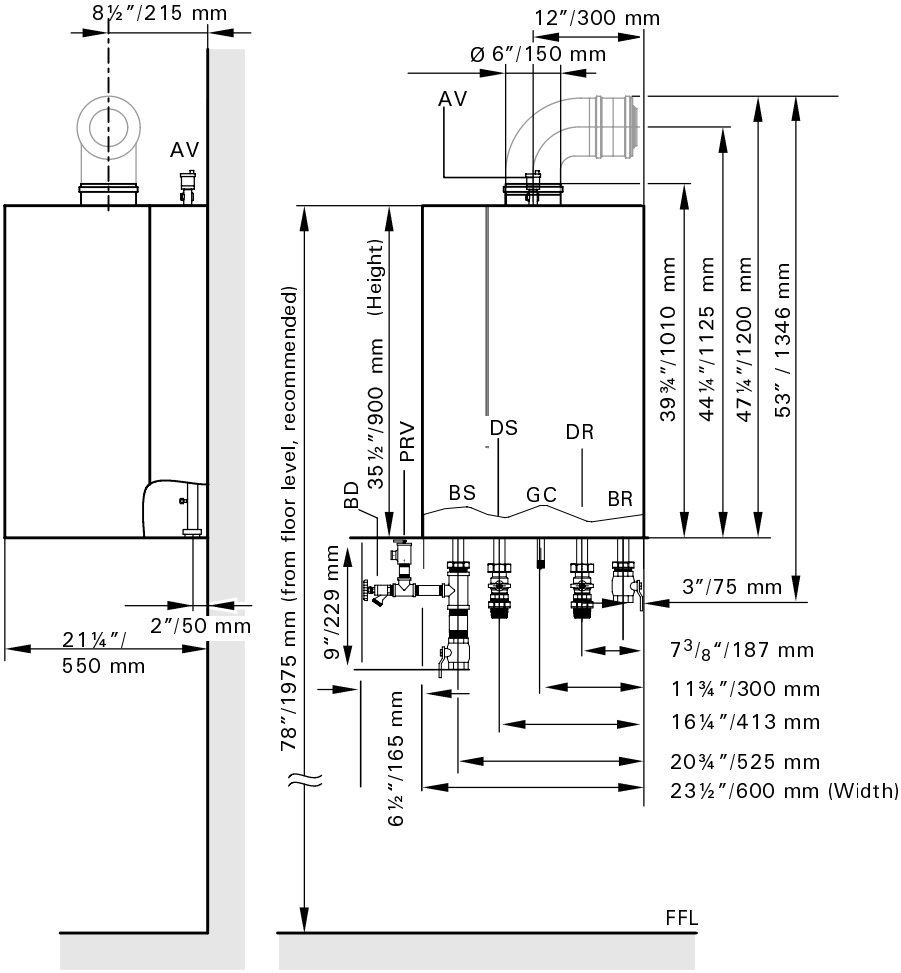

Legend

- AV Air Vent
- BD Boiler drain
- BR Boiler Return
- BS Boiler Supply
- DR Boiler heating return for domestic hot water production 1 1/4"
- DS Boiler heating supply for domestic hot water production 1 1/4"
- FFL Finished Floor Level
- GC Gas Connection
- PRV Pressure Relief Valve

Recommended Minimum Service Clearances

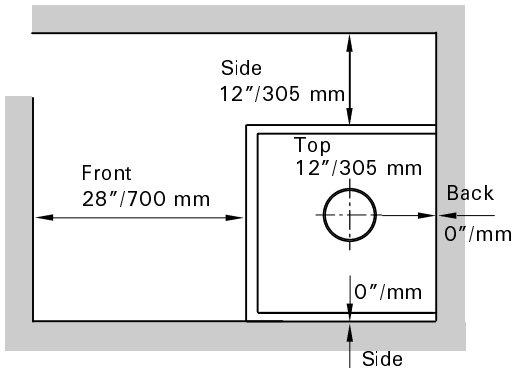

Minimum Clearances to Combustibles

Top	Front	Rear	Left	Right	Vent pipe*1
0	0 AL, CL	0	0	0	0

AL = Alcove

CL = Closet

*1 Refer to the Installation Instructions of the Vitodens 200 Venting System for details.

Note:

The Vitodens boiler has passed the zero inches vent clearance to combustibles testing requirements dictated by the Harmonized Standard ANSI Z21.13, CSA 4.9.2000 and therefore is listed for zero clearance to combustibles when vented with a single wall special venting system (AL-29-4C material). The zero inches vent clearance to combustibles for the Vitodens boiler supercedes the clearance to combustibles listing that appears on the special venting system label.

Technical Data

Waterside Flow (primary circuit)

The Vitodens 200 is designed only for closed loop, forced circulation hot water heating systems.

Pressure drop (primary circuit) of Vitodens 200

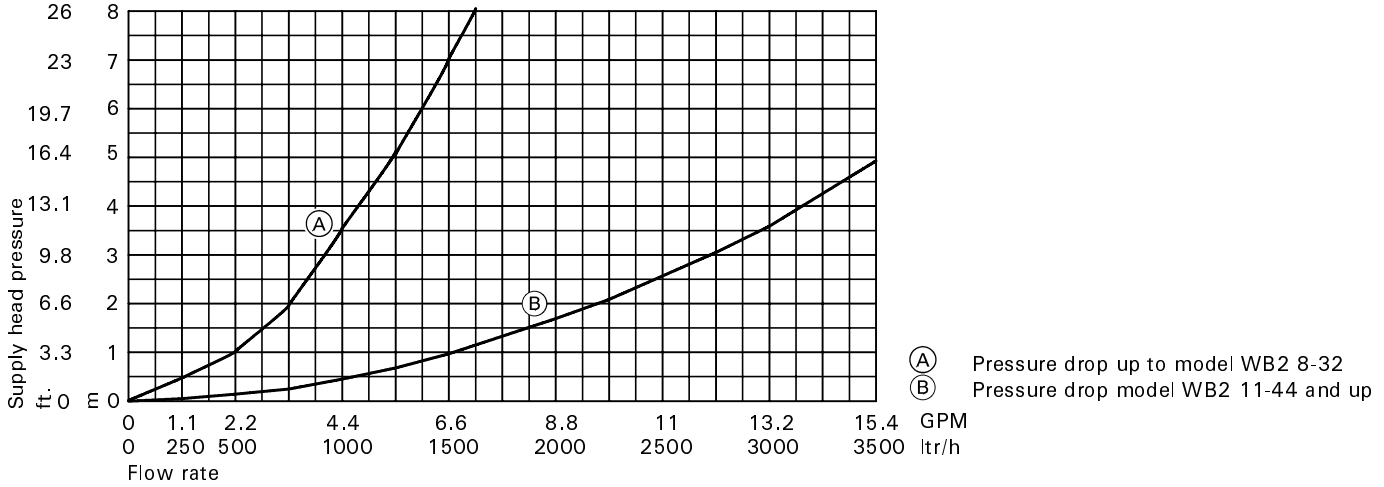

Typical System Flow Rates

Model	WB2	6-24C*	6-24	8-32	11-44	15-60
Δ t for NG						
Output (NG) Btu/h	81 000	81 000	112 000	154 000	206 000	
20 °F rise (GPM)	8.1	8.1	11.2	15.3	20.5	
25 °F rise (GPM)	6.5	6.5	9.0	12.2	16.4	
30 °F rise (GPM)	5.4	5.4	7.5	10.2	13.7	
35 °F rise (GPM)	4.6	4.6	6.4	8.7	11.7	
40 °F rise (GPM)	4.1	4.1	5.6	7.6	10.2	
Δ t for LP						
Output (LP) Btu/h	73 000	73 000	101 000	139 000	192 000	
20 °F rise (GPM)	7.3	7.3	10.1	13.8	19.1	
25 °F rise (GPM)	5.8	5.8	8.1	11.0	15.3	
30 °F rise (GPM)	4.9	4.9	6.7	9.2	12.7	
35 °F rise (GPM)	4.2	4.2	5.8	7.9	10.9	
40 °F rise (GPM)	3.7	3.7	5.1	6.9	9.6	

Use standard friction loss method for pipe sizing.

Observe boiler maximum and minimum flow rate limitations. If system flow rate exceeds boiler maximum flow rate (as stated on page 4) or if system flow rate is unknown, Viessmann strongly recommends the installation of a low-loss header. See page 22 for low-loss header information.

A low-loss header must be used when the **system** flow rate exceeds the maximum (or minimum) flow rate of the Vitodens 200 boiler. Once the low-loss header is connected, the built-in low-loss header logic of the Vitodens 200 boiler ensures the required Δ t across the system through the sensory communication between the low-loss header and the boiler.

*Please note that the low-loss header cannot be used with the Vitodens 200, WB2 6-24C Combi boiler.

Please see page 23 for details.

Heating Circuit Pumps

Built-in variable speed heating circuit pump for Vitodens 200 up to model WB2 8-32

Pump rotational speed is transmitted via an internal data BUS to the pump and adjusted by the control unit based on the outdoor temperature and the activation periods for normal and reduced heating.

In the factory default setting, the maximum pump rotational speed is preset to 2000 rpm (coding address "045") and the minimum pump speed to 1100 rpm (coding address "044").

Pump Model	Grundfos VIUPE-60 BUS	
Rated voltage	VAC	230
Rated current	A max.	0.45
	min.	0.21
Capacitor	µF	2.5
Power consumption	W max.	100
	min.	50

Vitodens 200 up to model WB2 8-32 (residual head pressure of built-in variable speed pump)

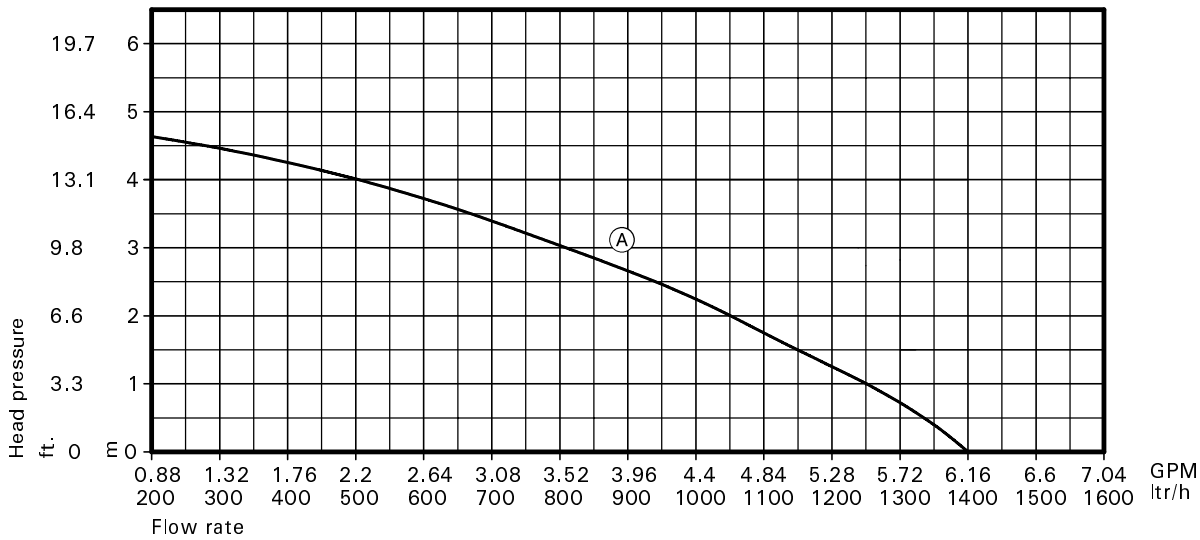

- Ⓐ With pump rotational speed set to 100% flow capacity (2700 rpm); see Coding Address 045 in the Vitodens 200 Start-up/Service Instructions. Pump factory default setting is 65% flow capacity (2000 rpm).

Field supplied system heating circuit pumps for Vitodens 200 (all models)

Viessmann offers a variety of prewired Grundfos system heating circuit pumps (see "Heating circuit pump (field supplied)" in the Installation Examples on pages 27 to 36) which meet typical Vitodens system installation requirements. See Price List for order information.

Heating Circuit Pumps/DHW Production

Heating Circuit Pumps (continued)

Recommended pumps for operation with Vitodens 200 model WB2 11-44 and up
(heating circuit pump, boiler pump and DHW pump field supplied)

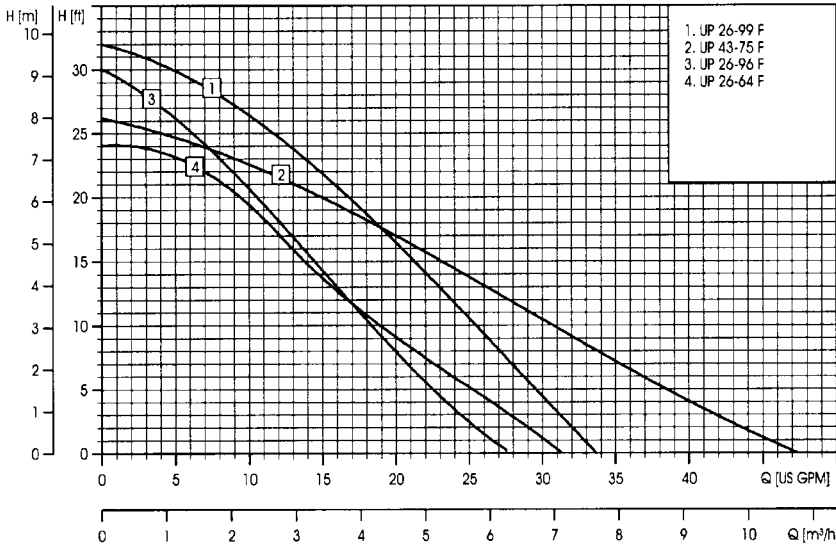

Performance chart courtesy of Grundfos.

IMPORTANT

Pump selection must be based on accurate system flow and pressure drop calculations (incl. DHW sizing). Viessmann offers a variety of prewired Grundfos circulating pumps which meet typical Vitodens system installation requirements.

See Price List for order information.

The following prewired standard Grundfos pumps are available for operation with the Vitodens 200, WB2-44/60 boilers:

- Model UP 26-99 F
- Model UP 43-75 F
- Model UP 26-96 F
- Model UP 26-64 F

Please reference corresponding performance curves (1-4) in the chart to the left.

DHW Production Planning

With integrated stainless steel plate heat exchanger for instantaneous DHW heating (model WB2 6-24C only) or with DHW connections for DHW production via a stand-alone DHW storage tank, the Vitodens 200 boiler series offers the right solution for every need.

Various factors must be taken into account when designing the DHW system, and when deciding between the Combi heating boiler with integrated DHW production and the standard heating boiler with DHW production via a stand-alone DHW storage tank.

Such factors are:

- DHW requirement, level of comfort and convenience
- Number of draw points
- Distance of draw points from the boiler/DHW storage tank
- System retrofit
- Space requirements

Options

		Gas-fired Combi boiler with instantaneous DHW production	Gas-fired standard heating boiler with stand-alone DHW storage tank
DHW requirement, level of comfort and convenience	DHW requirement for an apartment	+	+
	DHW requirement for a single-family house	0	+
	Central DHW requirement for a multi-family house	-	+
	Decentralized DHW requirement for a multi-family house	+	+
Number of draw points	One draw point	+	0
	Several draw points, non-simultaneous use	+	0
	Several draw points, simultaneous use	-	+
Distance of draw points from the boiler/DHW storage tank	Up to 23 ft./7 m (without DHW recirculation line)	+	-
	With DHW recirculation line	-	+
System retrofit	DHW storage tank already installed	-	+
	Replacement of existing Combi boiler	+	-
Space requirements	Minimal space available (installation in alcove)	+	0
	Adequate space available (boiler room)	+	+

+ = recommended 0 = recommended in certain cases - = not recommended

Domestic Hot Water Production via Instantaneous DHW Plate Heat Exchanger (Model WB2 6-24C)

The Vitodens 200 Combi boiler is equipped with an electronically controlled instantaneous DHW plate heat exchanger.

The comfort control function ensures that the instantaneous DHW plate heat exchanger is kept consistently at the required temperature (115°F / 46°C - off, 108°F / 42°C - on).

This translates into immediate availability of domestic hot water at any required temperature level.

Technical Data DHW Plate Heat Exchanger
See page 5 in this manual for technical data.

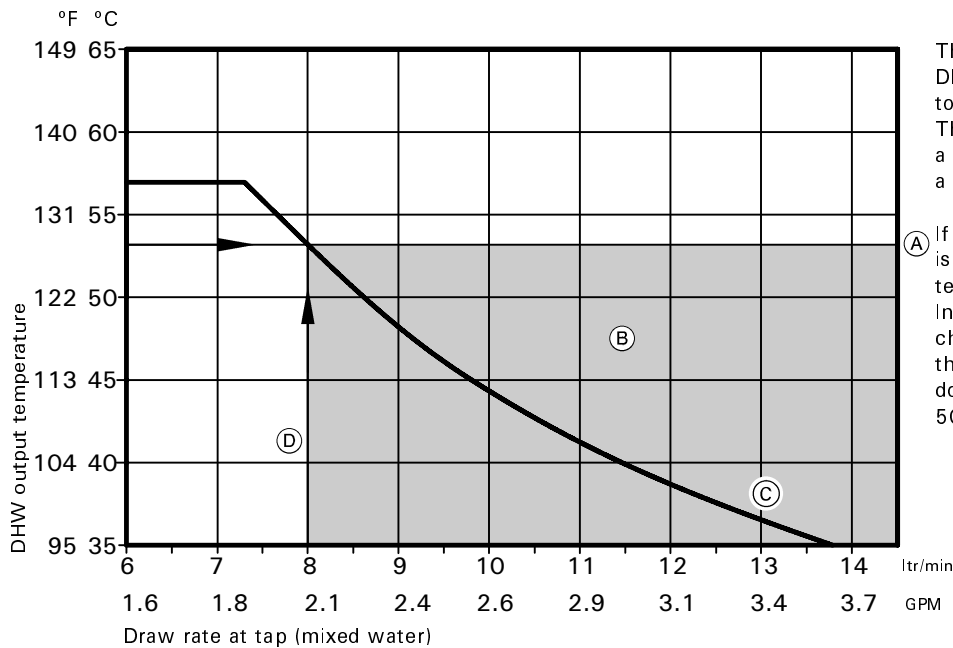

The diagram on the left illustrates how the DHW output temperature changes in relation to the draw rate at the tap. The DHW draw rate is restricted by means of a flow limiter to 2.1 GPM/8 ltrs per min. (D) at a temperature of 128 °F/53 °C.

(A) If more water is required, domestic cold water is added, resulting in a lower DHW output temperature. In the example to the left, demonstrating the change in DHW output temperature based on the addition of domestic cold water, a domestic cold water input temperature of 50 °F/10°C is assumed.

- (A) DHW output temperature at the Vitodens 200 boiler
- (B) DHW/DCW mixing zone
- (C) DHW output temperature at the mixing valve
- (D) Restriction by flow limiter

IMPORTANT

Vitodens 200, WB2 6-24C combi boilers cannot be connected to non-combi boilers in the field. Proper DHW sizing, including future DHW requirements, must be performed before selecting combi boilers.

DHW Production

Domestic Hot Water Production via DHW Storage Tank

Vitodens 200 boilers can be used in conjunction with the stand-alone DHW storage tanks offered by Viessmann. All Viessmann DHW storage tanks sold in North America are available in "Vitosilver" finish only.

Size and select the DHW storage tank based on the forecasted DHW consumption of the building in question.

For further technical information on DHW storage tanks, see the Vitocell-V Technical Data Manuals.

DHW Storage Tank Connection

for Vitodens models up to WB2 8-32

With installation fittings and built-in circulating pump for DHW production (via 3-way solenoid valve).

For the connection of the stand-alone DHW tank a DHW Production Kit is required. See Viessmann Price List for order information.

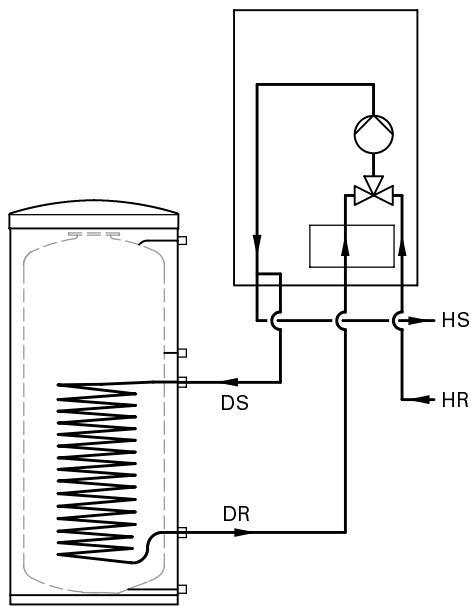

DHW Storage Tank Connection

for Vitodens model WB2 11-44 and up

With installation fittings and external circulating pump for DHW production (optional equipment).

For the connection of the stand-alone DHW tank a DHW Production Kit is required. See Viessmann Price List for order information.

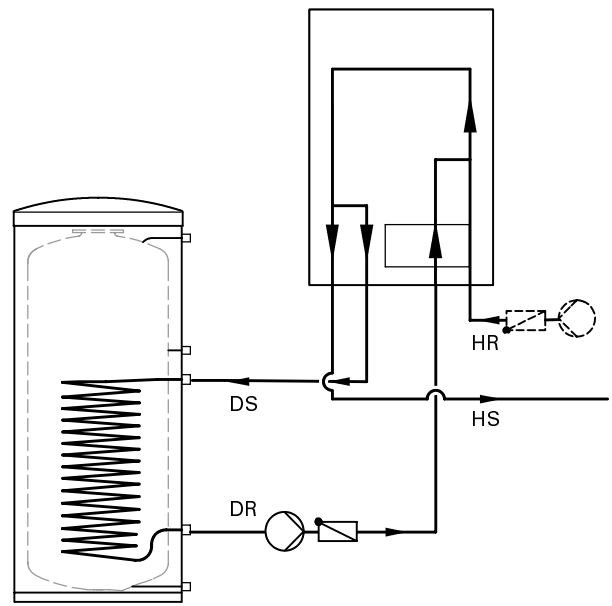

Legend

- DR Boiler heating return for domestic hot water production
- DS Boiler heating supply for domestic hot water production
- HR Heating Return
- HS Heating Supply

IMPORTANT

An adequately sized precharged expansion tank must be used. See Installation Examples for details.

DHW Recirculation

DHW recirculation lines increase the level of comfort and convenience of the domestic hot water supply and reduce water consumption.

These advantages directly derive from the immediate availability of domestic hot water at all draw points.

Poor insulation of the DHW recirculation line, however, can result in considerable heat loss.

Viessmann therefore recommends that effective insulation be provided and used for DHW recirculation lines of **23 ft./7 m in length or longer**.

In addition to a recirculation pump and a flow check valve, the DHW recirculation line should incorporate a programmed timer to switch off the recirculation pump overnight.

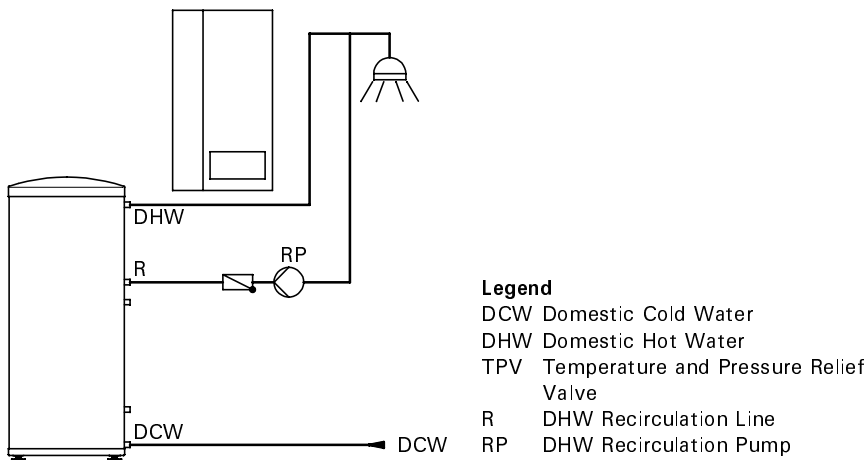

Vitocell-V stand-alone DHW storage tank

DHW Recirculation with Gas-Fired Combi Series

Due to the low water content of the plate heat exchanger, it is **not advisable** to connect a DHW recirculation line to the Vitodens Combi boiler.

Wall Mounting

Wall Mounting Information (up to model WB2 8-32)

Required accessories for installation without DHW storage tank

Mounting bracket
c/w mounting bolts and fittings

Additional requirements when connecting a DHW storage tank

DHW Production Kit for DHW storage tank connection

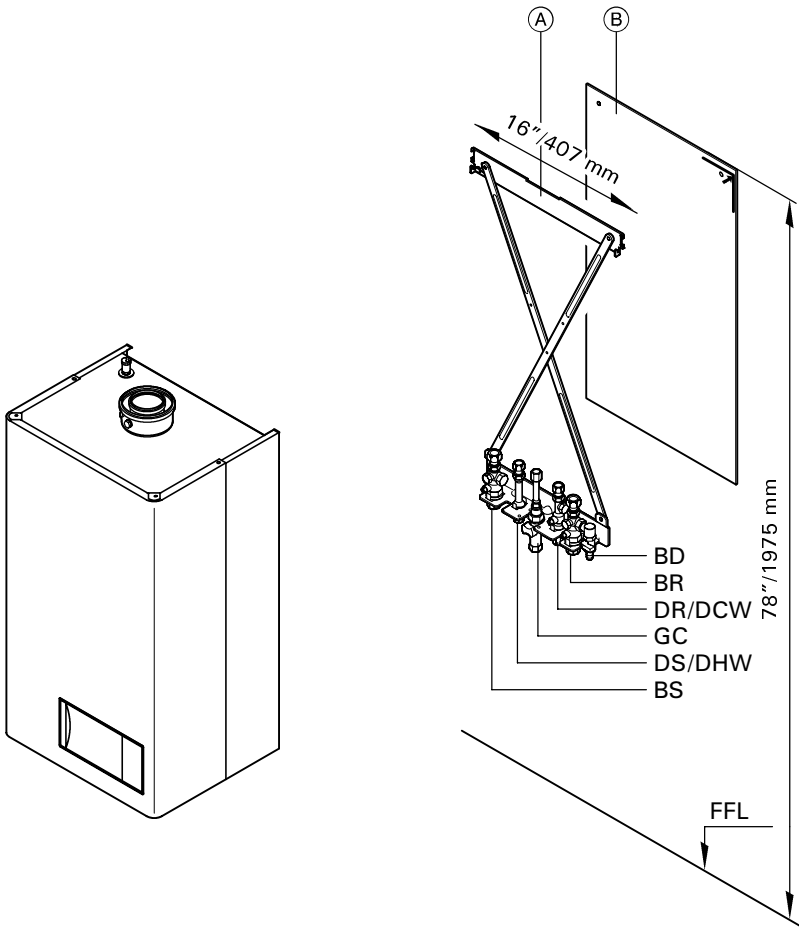

Illustration: Wall-mounting and connection of the Vitodens 200 Combi boiler (model WB2 6-24C)

Legend

BD Boiler Drain $\frac{3}{4}$ "
 BR Boiler Return $\frac{3}{4}$ "
 BS Boiler Supply $\frac{3}{4}$ "
 FFL Finished Floor Level
 GC Gas Connection $\frac{1}{2}$ "
 (gas shutoff valve is field supplied)

Only for Combi heating boiler
 DCW Domestic Cold Water $\frac{1}{2}$ "
 DHW Domestic Hot Water $\frac{1}{2}$ "

Only for standard heating boiler
 DR Boiler heating return for domestic hot
 water production $\frac{3}{4}$ "
 DS Boiler heating supply for domestic hot
 water production $\frac{3}{4}$ "

(A) Mounting bracket
 (B) Vitodens 200 installation location

Wall Mounting Information (model WB2 11-44 and up)

The Vitodens 200 (model WB2 11-44 and up) comes with a template, which allows you to easily mark the location of the screws for the mounting bracket and the location of the flue gas pipe on the wall.

The connection to the heating circuits (installation fittings are supplied in the Installation Fittings package supplied with the boiler) must be made on site.

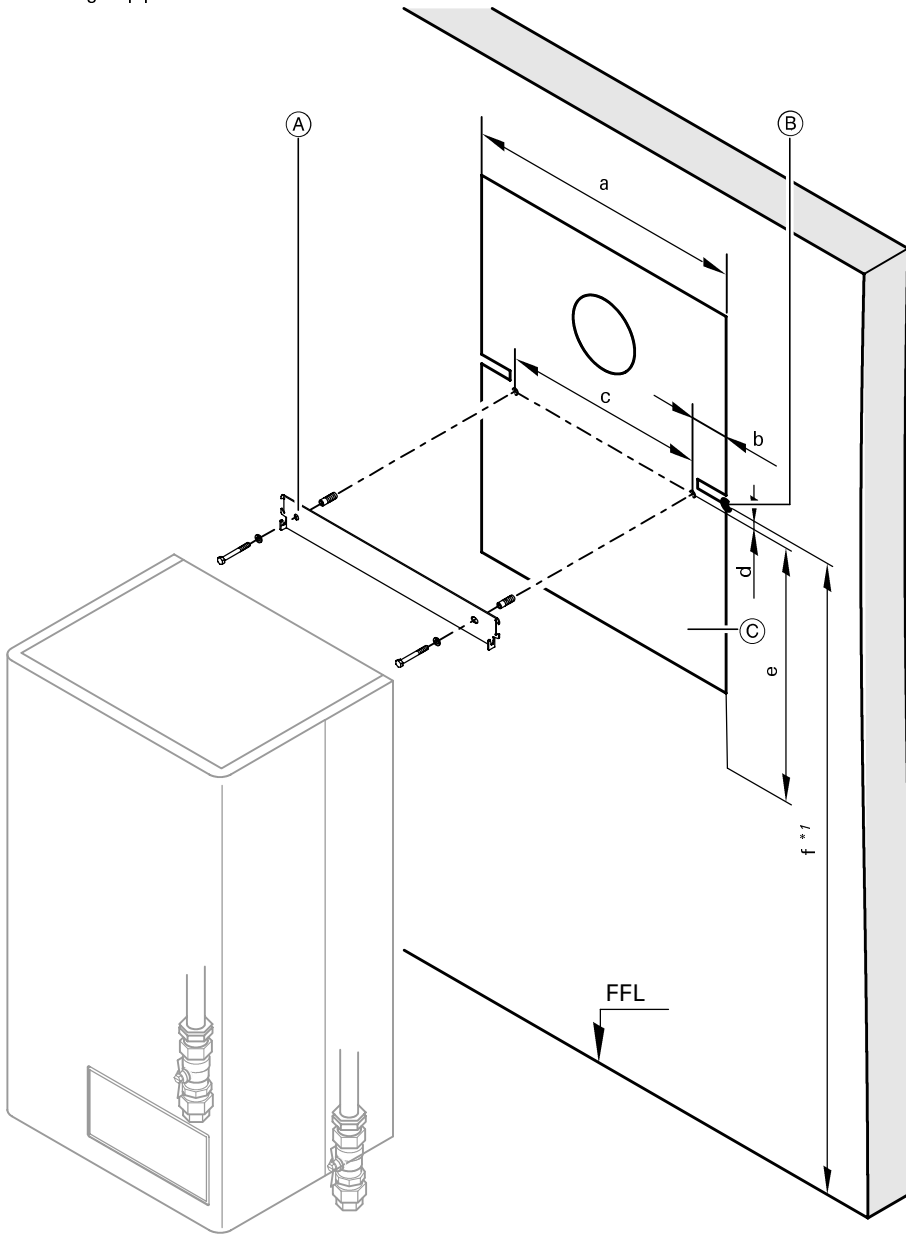

Illustration: Wall-mounting and connection of the Vitodens 200 standard heating boiler

- Ⓐ Reference point top edge Vitodens 200
- Ⓑ Mounting bracket
- Ⓒ Vitodens 200 mounting template

*1 Recommendation

Dimensions

- a 23 1/2" / 600 mm
- b 3 3/4" / 82 mm
- c 16" / 407 mm
- d 3/4" / 18 mm
- e 29" / 740 mm
- f 78" / 1975 mm

Condensate Connection/Neutralization Unit

Condensate Connection

Install the condensate drain pipe with a suitable gradient.
 Discharge condensate from the boiler into the drainage system, either directly or (if required) via a neutralization unit (accessory).

IMPORTANT

Pipe ventilation must take place between the siphon trap and the neutralization unit (if applicable).

Condensate Connection for Vitodens 200

■ up to model WB2 8-32

■ model WB2 11-44 and up

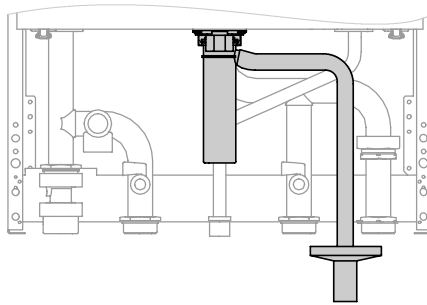
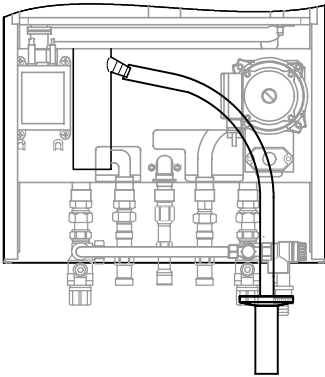

Condensate Drainage and Condensate Neutralization

The condensate formed both in the condensing boiler and in the flue gas pipe must be discharged into the public sewage system in accordance with all applicable local regulations.

The condensate produced by a gas-fired heating system has a pH value between 3 and 4.

Some local codes may require the use of a separate neutralization unit to treat the aggressive and corrosive nature of the condensate.

With a neutralization unit installed, all condensate from the boiler and the flue gas pipe enters into the neutralization unit where it is treated and released into the public sewage system with a safe pH value of above 6.5.

The use of neutralization granulate (performing the neutralizing process) is dependent on the operation of the heating system. To determine the required refill amount, check granulate level several times during the first year of operation. In some cases one granulate fill may last an entire year.

Contact Viessmann to order a neutralization unit for the Vitodens 200 boiler. See Viessmann Price List for order information.

The condensate discharge outlet to the drainage system connection must be clearly visible. It must be installed with a suitable gradient and provided with a stretch trap.

If the condensate outlet of the Vitodens 200 boiler is lower than the drain, a condensate pump must be used.

Only corrosion-resistant materials must be used for condensate drainage purposes (e.g. braided hose). Do not use galvanized materials or materials containing copper for piping, couplings etc.

The condensate drain must have a trap to prevent flue gas leakage.

Please note that other requirements might apply depending on local regulations and/or project-specific details.

It is advisable to contact your local waterworks office (authority responsible for waste water regulations) well before commencing with the installation of the neutralization unit in order to establish details of local regulations that apply.

The following table shows the concentration of (effluent) substances (e.g. heavy metals) contained in the waste water from the Vitodens 200 condensing boiler.

Condensate (effluent) substances	Values measured in mg/ltr	
	Vitodens 200	
Lead	<	0.01
Cadmium	<	0.005
Chromium	<	0.01
Copper	<	0.01
Nickel	<	0.01
Zinc	<	0.05
Tin	<	0.05

Vitodens 200 Venting Options

For an overview of venting options refer to the appendix starting on page 38 For detailed information refer to the Vitodens Venting System Installation Instructions (PN 5285 268).

Electrical Connection

Power Supply

The Vitodens 200 is shipped with a Power Module (up to model WB2 8-32) or with a Power/Pump Module (model WB2 11-44 and up). Both modules require a 120 VAC power supply from a wall receptacle. The modules contain a 120/230 VAC step-up transformer to power the Vitodens 200 with 230 VAC. Refer to the Installation Instructions shipped with the modules for wiring details.

Power Supply Connection of Accessories

The power supply connection of accessories can be made directly at the boiler control. The connection is activated and deactivated with the system on/off switch. The Dekamatik-HK1 control, the mixing valve accessory kit and the Solartrol control require a separate 120 VAC power supply from the wall receptacle.

2-wire cabling required for:

- outdoor temperature sensor
- Vitotronic 050/Dekamatik-HK1
- accessory kit for heating circuit with mixing valve
- remote switching of operating mode
- remote disable
- alarm output
- wall-mount base (when the programming unit is used as a remote control)

3-wire cabling required for:

- remote control RS/WS
- circulating pump

Control for Weather-Responsive Operation

Control for Weather-Responsive Operation

Built into the Vitodens 200 boiler is a menu-driven programming unit with...

- day and week feature and four programmable activation periods per day for reduced operation, activation of DHW production or activation of the DHW circulating pump
- freeze-up protection of entire heating system
- integrated diagnostic system
- integrated DHW tank temperature control

Constructional Design and Functions

Modular Structure

The control unit contains:

System on/off switch, override/emission test switch, comfort switch (operational only on Combi heating boiler), fixed high limit, adjustable high limit, digital display, micro-computer, adjustment options for switching times, for temperatures during normal and reduced operation, domestic hot water temperature, adjustment options for heating curves, temperature scanning options, built-in diagnostic system and fuses.

Boiler-Specific Functions

The control unit adjusts the boiler water temperature (= supply temperature of a direct-connected heating circuit and/or a heating circuit with mixing valve in conjunction with the accessory kit for a heating circuit with mixing valve) automatically and on a continuous basis to individual outdoor temperatures. The control has a DHW temperature controller with DHW priority switching (heating circuit pump off).

Technical Data

- Rated supply voltage: 120 VAC
Rated frequency: 60 Hz
Rated current: 12 A
Max. ambient temperature
- at operation: 32 to 104 °F
0 to 40 °C
For use in your living area or boiler rooms (with standard ambient conditions)
 - when storing or transporting: -4 to +149 °F
-20 to +65 °C

Max. operating temperature setting (space heating): 167 °F/75 °C

Adjustment range adjustable high limit (DHW production): 108 to 172 °F
42 to 78 °C

Setting fixed high limit: 210 °F/99 °C (not adjustable)

Adjustment range of DHW tank setpoint temperature: 50 to 140 °F
10 to 60 °C

Adjustment range heating curves

- Heating curve slope: 0.2 to 3.5
- Heating curve shift: 10 to 91 °F
-12 to +33 °C

Programming Unit

- Illuminated display with 8 text lines
- Menu-driven user guidance
- All settings, main codings and fault messages shown in plain text
- Holiday program
- Party button for switching to "normal operation" whenever required
- Energy savings button for lowering the desired room temperature by approx. 3.6 °F/2 °C in normal operation

The programming unit can be used as a remote control (wall-mount base must be ordered separately).

Timer Schedule of Programming Unit

Digital timer with day and week feature, calendar and automatic resetting to daylight savings time.

Timer of Programming Unit (continued)

Time, day and standard switching times are factory preset (individually programmable), up to four switching times selectable per day.

Shortest switching interval: 10 minutes
Power reserve: 5 years

Heating Programs

The freeze-up protection function*1 is active in all operating modes.

The following heating programs can be selected with the operating mode selector switch:

- Continuous standby
- DHW production only
- Normal operation/reduced operation or normal operation/standby

*1 See "Freeze-up Protection Function" below.

Freeze-up Protection Function

The freeze-up protection function is

- activated when the outdoor temperature drops below approx. 34 °F/1 °C. When the freeze-up protection function is activated, the heating circuit pump is activated and the boiler water is kept at a minimum temperature of approx. 68 °F/20 °C.
- deactivated when the outdoor temperature exceeds approx. 37 °F/3 °C.

Summer Operation

Heating program "☀"

The burner is only activated upon a call for domestic hot water from the DHW storage tank (controlled by DHW tank temperature sensor).

Heating Curve Adjustment (slope and shift)

The control unit regulates the boiler water temperature (= supply temperature of heating circuit without mixing valve) and the supply temperature of the heating circuit with mixing valve (in conjunction with the accessory kit for a heating circuit with mixing valve) according to the outdoor temperature.

The supply temperature that is required to achieve a given room temperature depends on the heating system and the thermal insulation of the building that is being heated.

The adjustment of the two heating curves is used to match the boiler water temperature and the supply temperature to these conditions.

Heating curves:

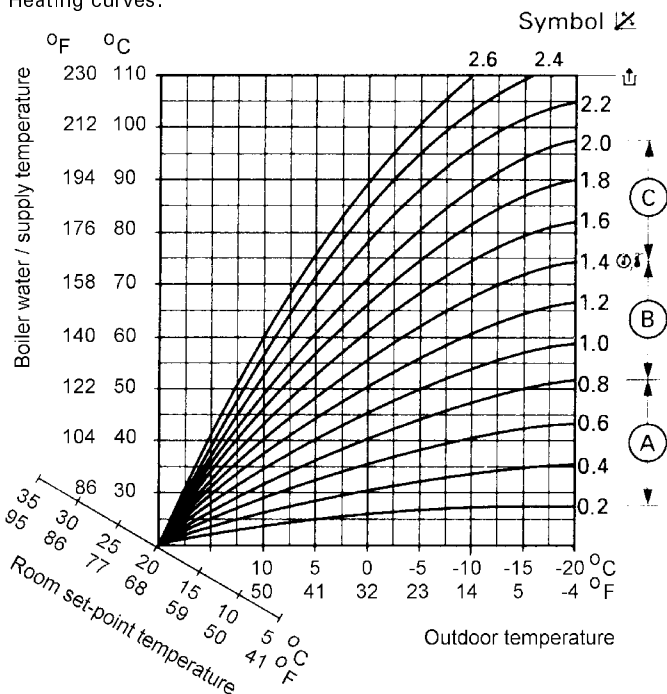

- (A) Low temperature heating system, e.g. radiant floor heating
- (B) Medium temperature heating system, e.g. cast iron radiation, staple-up radiant floor heating
- (C) High temperature heating system, e.g. fintube radiation, fan coils

The boiler water temperature is limited upwards by the fixed high limit and the temperature set for the electronic high limit. The supply temperature cannot rise above the boiler water temperature.

Boiler Temperature Sensor

The boiler temperature sensor is connected at the control unit for weather-responsive operation and is built into the boiler.

Max. ambient temperature

- at operation: 32 to 266 °F
0 to 130 °C
- when storing or transporting: -4 to +158 °F
-20 to +70 °C

Outdoor Temperature Sensor

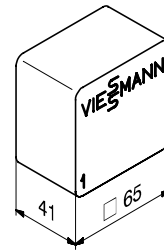

Sensor location:

- North or northwest wall of building
- 6.6 to 8.2 ft./2 to 2.5 m above ground or in case of a multi-storey building approx. halfway up the second floor

Electrical connection:

- 2-wire cable, max. cable length 115 ft./35 m with a wire size of min. AWG 16 copper
- Cable to the outdoor sensor must not be laid near line voltage wiring (120/240 V)

Max. ambient temperature at operation, when storing

- or transporting: -40 to +158 °F
-40 to +70 °C

DHW Tank Temperature Sensor

Part No. 7134 239

Supplied with:

- installation fittings for horizontal DHW storage tanks (42 to 120 USG/160 to 450 ltr) (DHW tank must be ordered separately at time of order)
- installation fittings for vertical DHW storage tanks (42 to 120 USG/160 to 450 ltr) (DHW tank must be ordered separately at time of order)
- DHW production kit for Vitodens 200
Cable length approx. 13 ft./3.75 m, ready to plug in

Max. ambient temperature

- at operation: 32 to 194 °F
0 to 90 °C
- when storing or transporting: -4 to +158 °F
-20 to +70 °C

Control for Weather-Responsive Operation Accessories

Control for Weather-Responsive Operation Accessories

Mixing Valve Actuator Accessory Kit, Part No. 7133 392

Mixing valve actuator

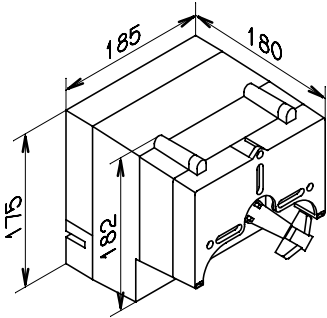

The mixing valve actuator is mounted directly on the Viessmann ¾ to 2½" mixing valve.

The mixing valve actuator is a motor-driven control unit. The rotational direction is reversible.

The mixing valve actuator comes with a plug-in connector for a heating circuit pump, supply temperature sensor (strap-on sensor with 19.7 ft./6 m connecting cable), power supply connecting cable (10 ft./3 m) and a connecting cable (10 ft./3 m) for the KM-BUS Expansion Module.

Rated voltage: 120 VAC

Rated frequency: 60 Hz

Rated current: 4 (2) A

Power consumption: 4 W

Max. ambient temperature

■ at operation: 32 to 104 °F
0 to 40 °C

■ when storing
or transporting: -4 to +149 °F
-20 to +65 °C

Relay output for
heating circuit pump: 4(2) A, 120 VAC

Actuator

torque: 3 Nm

Time of 90 °✶: 2 minutes

Supply Temperature Sensor (strap-on sensor, included with mixing valve actuator accessory kit), Part No. 7133 895

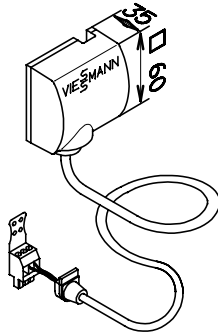

Installed with a strapping band.

Cable length 19.7 ft./6 m, ready to plug in.

Max. ambient temperature

■ at operation: 32 to 212 °F
0 to 100 °C

■ when storing
or transporting: -4 to +149 °F
-20 to +70 °C

Viessmann 2-Wire BUS Expansion Module, Part No. 7134 276

for connecting a Vitotronic 050 or a Dekamatik-HK heating circuit control, a Vitocom 200, a Vitocom 300 or a Solartronic control.

Comprises one circuit board.

Setting range: 86 to 212 °F

30 to 100 °C

Operating differential: 8 °C

Wall-Mount Base with Blank Cover, Part No. 7133 385

(used when the programming unit of the control is used as remote control)

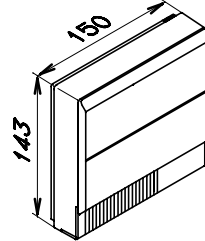

All functions of the programming unit can be used.

WS function: Unit can be mounted anywhere in the building.

RS function: The remote control is mounted on an inside wall of the main living area opposite radiators, not in shelves, alcoves or next to doors or sources of heat (e.g. in direct sunlight, next to a fireplace, TV, etc.).

Electrical connection:

■ 2-wire cable, max. cable length 98 ft./30 m with a wire size of min. AWG 16 copper

■ Cable to the outdoor sensor must not be laid near line voltage wiring (120/240 V)

Max. ambient temperature

■ at operation: 32 to 104 °F
0 to 40 °C

■ when storing
or transporting: -4 to +149 °F
-20 to +65 °C

Boiler Temperature Indication Unit,
Part No. 7133 384

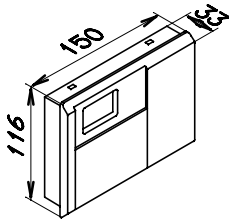

Must be inserted into the control unit for weather-responsive operation when the programming unit of the control is used as remote control.
Boiler water temperature and fault messages are displayed.

Temperature Sensor for Low-Loss Header,
Part No. 7134 240

Supply temperature sensor for the common supply in applications with a low-loss header.

Installed with a strapping band.
Cable length approx. 12 ft./3.75 m, ready to plug in.

Max. ambient temperature

- at operation: 32 to 104 °F
0 to 90 °C
- when storing or transporting: -4 to +149 °F
-20 to +70 °C

Remote Control WS
Part No. 7133 380

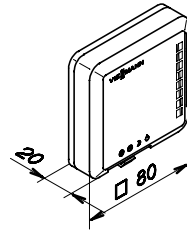

The remote control unit is used to set the desired temperatures for normal operation (daytime temperature) and reduced operation (night setback temperature) of one heating circuit from any chosen room in the building.

Only one remote control unit can be connected. If a heating circuit with mixing valve is installed, the remote control controls the heating circuit with mixing valve.

Electrical connection:

- 3-wire cable (without "green/yellow" wire), max. cable length 98 ft./30 m with a wire size of min. AWG 16 copper
- Cable to the WS control sensor must not be laid near line voltage wiring (120/240 V)

Max. ambient temperature

- at operation: 32 to 104 °F
0 to 40 °C
- when storing or transporting: -4 to +149 °F
-20 to +65 °C

Setting range for room temperature setpoint

- Selector knob "☀": 57 to 79 °F
14 to 26 °C
- Selector knob "☾": 45 to 73 °F
7 to 23 °C

Desired room

- temperature when selector switch is set to "☀": 37 to 41 °F
3 to 5 °C

Remote Control RS
Part No. 7133 381

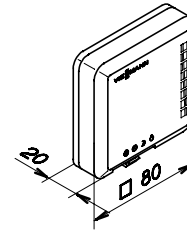

The remote control unit is used to set the desired temperatures for normal operation (daytime temperature) and reduced operation (night setback temperature) of one heating circuit from the main living area.

The built-in room temperature sensor measures the room temperature and initiates any necessary correction of the supply temperature.

Only one remote control unit can be connected. If a heating circuit with mixing valve is installed, the remote control unit controls the heating circuit with mixing valve.

The remote control unit is mounted on an inside wall of the main living area opposite radiators, but not in shelves, alcoves or immediately next to doors or sources of heat (e.g. in direct sunlight, next to a fireplace, TV etc.).

Electrical connection:

- 3-wire cable (without "green/yellow" wire), max. cable length 98 ft./30 m with a wire size of min. AWG 16 copper
- Cable to the RS control sensor must not be laid near line voltage wiring (120/240 V)

Note on the room temperature sensing function (RS function) when using a remote control

Due to the "inertia" of underfloor heating systems, the RS function **must not** be used for an underfloor heating circuit.

Max. ambient temperature

- at operation: 32 to 104 °F
0 to 40 °C
- when storing or transporting: -4 to +149 °F
-20 to +65 °C

Setting range for room temperature setpoint

- Selector knob "☀": 57 to 79 °F
14 to 26 °C
- Selector knob "☾": 45 to 73 °F
7 to 23 °C

Desired room

- temperature when selector switch is set to "☀": 37 to 41 °F
3 to 5 °C

Control for Weather-Responsive Operation/Vitodens 200 Accessories

Room Temperature Sensor, Part No. 7133 379

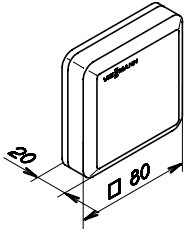

Separate room temperature sensor used in addition to the RS remote control for applications where the RS remote control unit cannot be positioned in the main living area or in a suitable location for temperature measurement/setting purposes.

The room temperature sensor is mounted on an inside wall of the main living area opposite radiators, but not in shelves, alcoves or immediately next to doors or sources of heat (e.g. in direct sunlight, next to a fireplace, TV etc.).

The room temperature sensor is connected to the RS remote control unit.

Electrical connection:

- 2-wire cable with a wire size of min. AWG 16 copper
- The cable length between the control unit, remote control unit and room temperature sensor must not exceed 98 ft./30 m
- Cable to the outdoor sensor must not be laid near line voltage wiring (120/240 V)

Max. ambient temperature

- at operation: 32 to 104 °F
0 to 40 °C
- when storing or transporting: -4 to +149 °F
-20 to +65 °C

Expansion Board,

for Vitodens 200 up to model WB2 8-32
Part No. 7134 209

for Vitodens 200 model WB2 11-44 and up
Part No. 7134 211

With the installation of an expansion board the following capabilities are added:

- Connection of an additional heating circuit pump (only for models up to WB2 8-32)
- Connection of a dry contact to operate an external alarm with the following ratings: 24/250 V, 5 A

Please see following table.

	Pump	Alarm
WB2-24C	--	■
WB2-24	■	■
WB2-32	■	■
WB2-44	--	■
WB2-60	--	■

Accessories for Vitodens 200

Neutralization Unit for Single-Boiler Applications

with neutralizing granulate

for Vitodens 200 up to model WB2 8-32
Part No. 7134 231

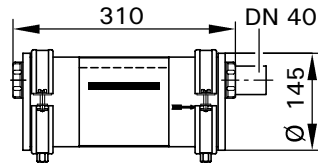

for Vitodens 200 model WB2 11-44 and up
Part No. 7134 232

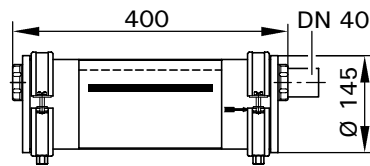

Neutralization Pellets

(4.4 x 2.9 lbs./2 x 1.3 kg)
Part No. 9524 670

For refill or replacement purposes

Cosmetic Piping Cover for Installation Fittings

to cover water and gas fittings and piping, for Vitodens 200 up to model WB2 8-32
Part No. 7339 571

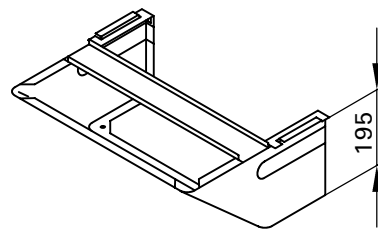

Conversion Kit

for fuel conversion in the field from
-natural gas to liquid propane
-liquid propane to natural gas

(When ordering, please state
-type of fuel conversion
-boiler model no.)

Low-Loss Header

(not applicable to Combi Series boilers!)

-Type 80/50

Part No. 7134 230

(max. flow rate 17.6 GPM / 4 m³/h)

-Type 120/80

Part No. 7134 244

(max. flow rate 35.2 GPM / 8 m³/h)

-Type 160/80

Part No. 7134 293 *1

(max. flow rate 44 GPM / 10 m³/h)

-Type 200/120

Part No. 7134 294 *1

(max. flow rate 80 GPM / 18 m³/h)

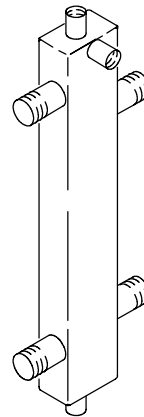

When used in conjunction with the Vitodens 200 boiler, the low-loss header acts as hydraulic break, decoupling boiler and system circuits from each other. It is recommended to use the low-loss header in applications in which the total system flow rate exceeds the maximum (or minimum) boiler flow rate.

For maximum boiler flow rates, see table on page 8 in this manual.

Viessmann strongly recommends the use of a low-loss header in cases where the system head and flow rates are unknown.

*1 Floor-mounted version (typically used for multiple-boiler installations).

Continued on following page...

Accessories for Vitodens 200 (continued)

The temperature sensor connection [TS] typically located at the top of the low-loss header ensures low return temperatures to the Vitodens 200 boiler at all times, increasing operational efficiency. In addition, the low-loss header helps eliminate air and debris [D] from the heating system.

See figures on the right for an illustration of the principle of operation.

The low-loss header is available in the following sizes. Select the size based on the maximum system flow rate of your application.

Model No.	Max. system flow rate
Type 80/50	17.6 GPM / 4 m ³ /h
Type 120/80	35.2 GPM / 8 m ³ /h
Type 160/80*1	44 GPM / 10 m ³ /h
Type 200/120*1	80 GPM / 18 m ³ /h

*1 Product does not look exactly as illustrated.

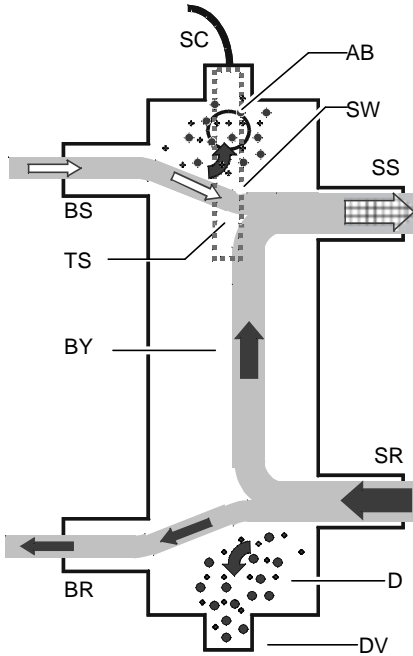

Low-loss header design (Type 80/50 or 120/80)

Legend

- AB Air Bleed
- BR Boiler Return
- BS Boiler Supply
- BY Bypass (with laminar flow)
- D Debris and/or air
- DV Drain Valve
- SC Sensor Cable
- SR System Return
- SS System Supply
- TS Viessmann Temperature Sensor
- SW Sensor Well

IMPORTANT

Use only a Viessmann supplied temperature sensor. Do not use any other manufacturer's temperature sensor.

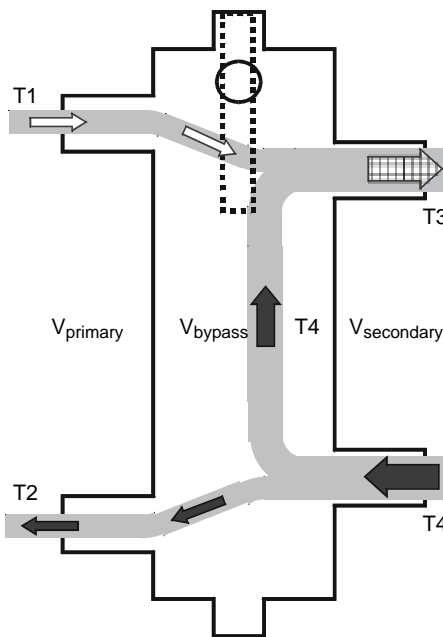

Principle of Operation

- T1 Boiler supply temperature
- T2 Boiler return temperature
- T3 System supply temperature
- T4 System return temperature
- V_{primary} Boiler circuit flow rate
- V_{secondary} Heating circuit flow rate
- V_{bypass} Bypass flow rate
- Q_{primary} Heat supplied by boiler
- Q_{secondary} Heat consumed by system

$$V_{primary} < V_{secondary}$$

$$T1 > T3$$

$$T2 = T4$$

$$Q_{primary} = Q_{secondary}$$

$$T1 \leq 167^{\circ}F / 75^{\circ}C$$

$$V_{secondary} = V_{primary} + V_{bypass}$$

IMPORTANT

When installing a low-loss header, system mixed supply temperature (T3) must be calculated as follows:

$$T3 = \frac{T1 \times V_{primary} + T4 \times V_{bypass}}{V_{secondary}}$$

Standard Equipment

Standard Equipment

The Vitodens 200 gas-fired condensing boiler with Inox-Radial heat exchanger surfaces, modulating Matrix-compact gas burner for natural gas and liquid propane, aqua-plate with plug-in connection system c/w

- pressure gage and KM-BUS variable speed pump (for WB2 6-24C, 6-24 and 8-32 only)
- installation fittings with 30 psig pressure relief valve and air vent
- boiler control unit with outdoor temperature sensor, power module (up to model WB2 8-32) or power/pump module (model WB2 11-44 and up)

- The boiler comes fully piped and prewired.
- The Vitodens 200 Combi boiler is equipped with an integrated stainless steel plate heat exchanger for instantaneous DHW heating.
- **Venting material (coaxial) is to be supplied by Viessmann only. Side wall vent installations must include Viessmann protective screen!**
- Enclosure finish:
 - black steel, powder-coated white
- The Vitodens 200 comes ready for use with natural gas and can be fuel converted to liquid propane.

Wall mounting componentry

The following wall mounting components are supplied with the Vitodens 200 boiler:

- Mounting bracket (comes preinstalled for models up to WB2 8-32)
- Mounting bolts
- Installation fittings
- Screws for mounting bracket on
 - wood studs (2" x 4")
 - metal studs
 - brick/concrete wall

How the Vitodens 200 boiler operates...

The MatriX burner blower and the combination gas valve are factory calibrated and pre-adjusted for optimum boiler performance at all firing rates through a non-mechanical, pneumatic modulating link between combustion air and gas flows. Blower speed is automatically increased or decreased based on heat demand and venting system resistances, thereby regulating the amount of combustion air drawn. The pneumatic modulating link between air and gas introduces the required amount of gas for correct combustion to meet the current heat demand, based on a linear relationship between ΔP air and ΔP gas. The optimum combustion air flow rate is recognized and monitored by the differential air pressure sensor (transducer). The output voltage signal of the transducer is analyzed for logic by the LGM 29 burner control unit. The LGM 29 burner control unit contains pre-programmed performance curves and operational safety parameters unique for every boiler model.

Flue gas adaptation function

The Vitodens 200 has a flue gas adaptation function. This function records, processes, and reacts in real time to fluctuations in pressure drop in the vent air-intake pipe during normal operation caused by partial pipe blockages due to ice formation at the vent termination, debris and/or sudden high winds. Such increase in pressure drop, if not promptly corrected, will reduce the combustion air flow rate, and hence lead to unstable combustion. The differential air pressure sensor (transducer) records such pressure drops and supplies voltage signals to the LGM 29 burner control unit which, in turn (based on stored performance curves and safety parameters), initiates prompt adjustment of the blower rotational speed, thus readjusting the combustion air flow rate for optimum combustion. The same automatic adaptation logic applies if combustion air is reduced (or increased) due to slower (or faster) blower speed resulting from line voltage drops (or increases) below (or above) the threshold of 85% (or 110%).

Installation Examples

IMPORTANT

The examples on the following pages depict possible piping layouts of the Vitodens 200 boiler equipped with Viessmann System Technology.

For boiler and tank combinations, please install only feasible combinations listed in the Viessmann Price List.

Please note that the following examples are simplified conceptual drawings only! Piping and necessary componentry must be field verified.

A low water cut-off (LWCO) must be installed where required by local codes. Proper installation and functionality in the field is the responsibility of the heating contractor.



WARNING

If a DHW storage tank other than a Viessmann Vitocell 100 or 300 tank is used, the installer must verify proper operation of the Viessmann DHW tank temperature sensor with the original manufacturer of the tank. Viessmann strongly recommends the installation of a temperature tempering valve in the DHW supply line.

Installation Examples

System Layout 1

Vitodens 200 (model WB2 6-24C) with a direct-connected heating circuit

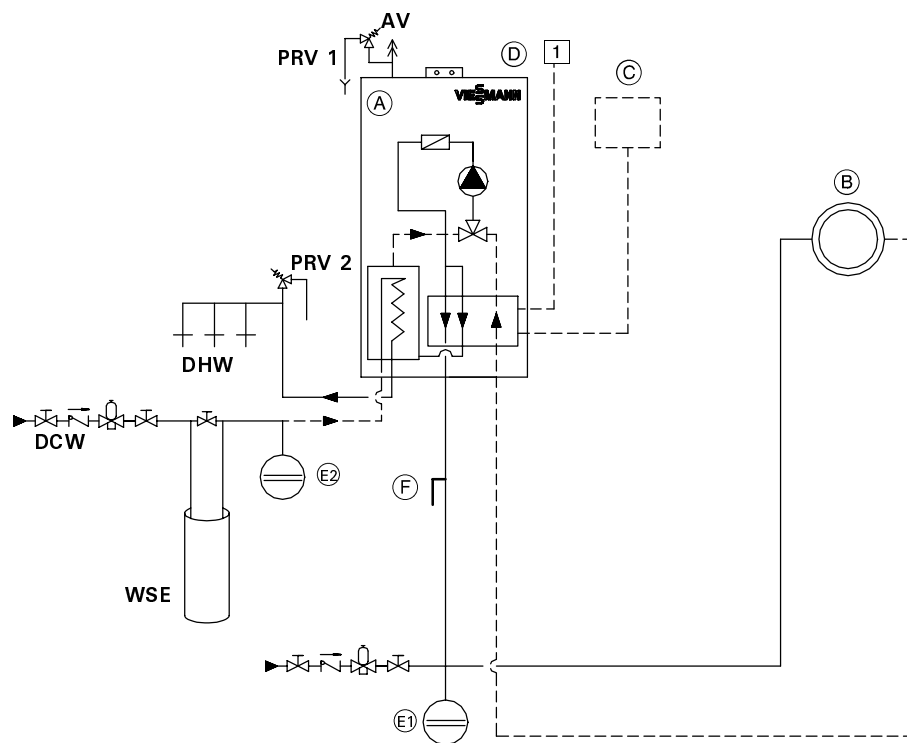

AV Air vent
 DCW Domestic cold water
 DHW Domestic hot water
 PRV 1 Pressure relief valve (30 psig)
 PRV 2 Pressure relief valve (150 psig)
 WSE Water softening equipment/filter

(A) Vitodens 200 gas-fired Combi boiler
 (B) Heating circuit
 (C) Remote control for programming unit
 (D) Outdoor temperature sensor of control unit for weather-responsive operation ¹
 (E1) Precharged expansion tank
 (E2) Precharged expansion tank (required where backflow preventer is installed; check local plumbing codes and requirements)
 Expansion tank pressure rating must be greater than 150 psig and suitable for potable water applications
 (F) Optional purge tee (field supplied) for easier air removal

Important:
 Please note location of expansion tank

IMPORTANT

The low-loss header cannot be used with the Vitodens 200 Combi Series boiler, WB2 6-24C. The WB2 6-24C is specifically designed for small, "one-temperature" apartments or bungalows, where flow and head requirements are low and can be handled by the built-in heating circuit pump.

Upon a call for DHW, the built-in diverting solenoid valve is energized. The boiler hot water is diverted to the DHW loop at maximum pump rotational speed (no variable speed pump operation during DHW production). Once the DHW instantaneous plate heat exchanger is satisfied, the built-in diverting solenoid valve is de-energized and heating operation resumes.

The built-in plate heat exchanger is equipped with two independent temperature safety features, one surface-mounted limit temperature switch on the heating boiler side and one temperature immersion control sensor on the DHW side.

IMPORTANT

Do not use the expansion board to control a separate system heating circuit pump with Vitodens 200 Combi Series boiler, WB2 6-24C.

A heating circuit pump controlled by an expansion board will run as a DHW recirculation pump in parallel to the demand for domestic hot water rather than as intended.

System Layout 2

Vitodens 200 (up to model WB2 8-32) with...

- DHW storage tank
- one direct-connected heating circuit
- one heating circuit with a mixing valve

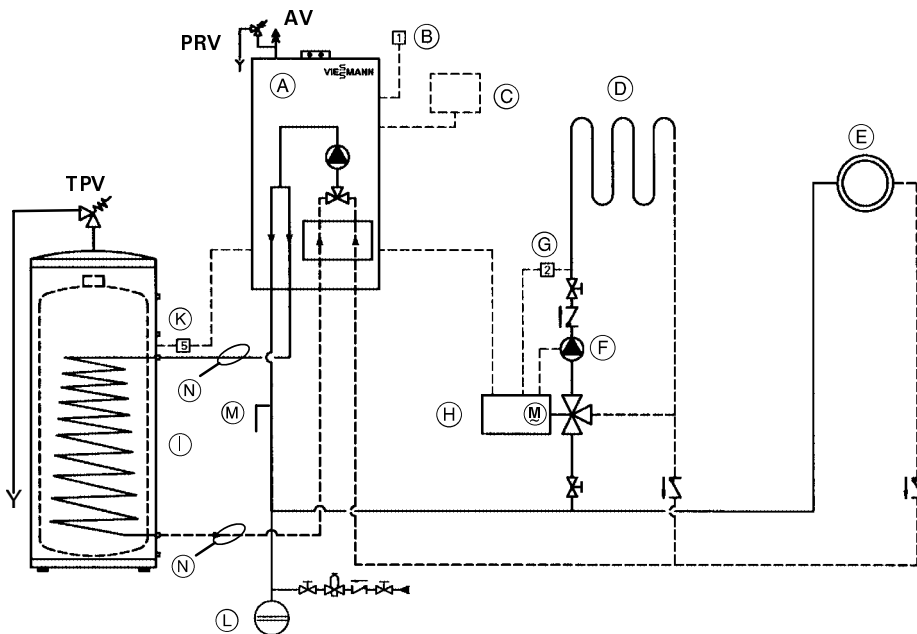

AV Air vent
 PRV Pressure relief valve
 TPV Temperature and pressure relief valve

- (A) Vitodens 200 gas-fired condensing boiler with programming unit for weather-responsive operation
- (B) Outdoor temperature sensor [1]
- (C) Remote control for programming unit
- (D) Underfloor heating circuit
- (E) Radiator heating circuit
- (F) Heating circuit pump (field supplied)
- (G) Mixing valve temperature sensor [2]
- (H) Accessory kit for a heating circuit with mixing valve
- (I) Domestic hot water storage tank
- (K) DHW tank temperature sensor [5]
- (L) Expansion tank
- (M) Optional purge tee (field supplied) for easier air removal
- (N) DHW supply and return piping

Important:
 Please note location of expansion tank

Installation of different heating circuits...

- radiator heating circuit (high temperature circuit)
- underfloor heating circuit with 3-way mixing valve (low temperature circuit)
- DHW production

...with the following flow conditions

1. The water flow rate (output) of the radiator heating circuit is at least 30% greater than that of the underfloor heating circuit.
2. The total flow rate of the two heating circuits is less than the maximum possible water flow rate of the Vitodens 200 (see following table).

Model No.	Max. flow rate (GPM/ltr/h)
Vitodens 200,	
WB2 6-24C	6.2/1400
WB2 6-24	6.2/1400
WB2 8-32	7.0/1600

The use of a low-loss header is strongly recommended if the maximum water flow rate in the application concerned exceeds the values shown in the table above, or if the system flow rates are unknown. The low-loss header is available as accessory part. See the following pages for installation examples with a low-loss header.

The 3-way mixing valve, built-in to achieve the low temperature level of the underfloor heating circuit, is controlled by an accessory kit for a heating circuit with mixing valve. The circulation pump built into the Vitodens 200 boiler supplies the radiator heating circuit. The underfloor heating circuit is supplied by a circulation pump installed on site which is controlled by the accessory kit.

Upon a call for DHW, the built-in diverting solenoid valve is energized. The boiler hot water is diverted to the DHW loop at maximum pump rotational speed (no variable speed pump operation during DHW production). Once the DHW tank is satisfied, the built-in diverting solenoid valve is de-energized and heating operation resumes.

IMPORTANT

DHW supply and return piping between boiler DHW connections and the Viessmann DHW tank connections (N), shall be a minimum of 1" nominal pipe diameter (irrespective of the 3/4" DHW connection outlet sizes provided on the boiler and the DHW tank). This will ensure the residual head of the built-in pump is fully utilized to overcome the resistance of the DHW heat exchanger coil and to provide sufficient water flow to the boiler heat exchanger.

In non-Viessmann DHW tank applications, perform, in addition to the above, accurate calculations for DHW tank coil pressure drop versus boiler pump residual head to ensure sufficient water flow to the boiler heat exchanger. Failure to heed the above instructions may cause boiler short-cycling and inadequate DHW supply.

Installation Examples

System Layout 3

Vitodens 200 (up to model WB2 8-32) with...

- DHW storage tank
- one heating circuit with mixing valve
- one heating circuit without mixing valve and low-loss header

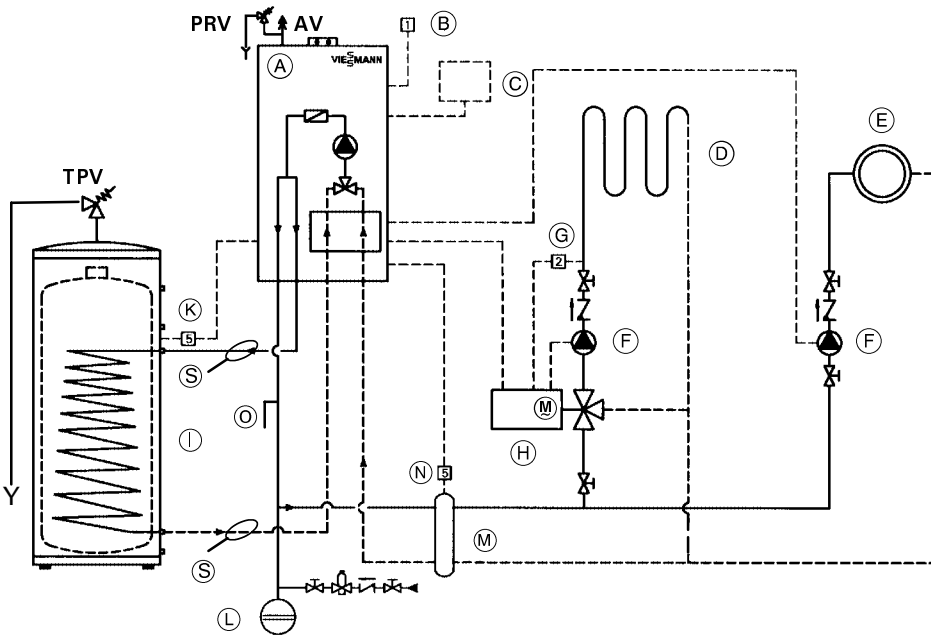

Important:
Please note location of expansion tank

- AV Air vent
- PRV Pressure relief valve
- TPV Temperature and pressure relief valve
- (A) Vitodens 200 gas-fired condensing boiler with programming unit for weather-responsive operation
- (B) Outdoor temperature sensor 1
- (C) Remote control for programming unit
- (D) Underfloor heating circuit
- (E) Radiator heating circuit
- (F) Heating circuit pumps (field supplied)
- (G) Mixing valve temperature sensor 2
- (H) Accessory kit for a heating circuit with mixing valve
- (I) Domestic hot water storage tank
- (K) DHW tank temperature sensor 5
- (L) Expansion tank
- (M) Low-loss header
- (N) Viessmann temperature sensor for low-loss header 5
- (O) Optional purge tee (field supplied) for easier air removal
- (S) DHW supply and return piping

Installation of different heating circuits...

- radiator heating circuit (high temperature circuit)
- underfloor heating circuit with 3-way mixing valve (low temperature circuit)
- DHW production

...with the following flow conditions

1. The total flow rate of the two heating circuits is **greater** than the maximum possible water flow rate of the Vitodens 200 (see following table).

Model No.	Max. flow rate (GPM/ltr/h)
Vitodens 200,	
WB2 6-24C	6.2/1400
WB2 6-24	6.2/1400
WB2 8-32	7.0/1600

The use of a low-loss header is therefore recommended.
The low-loss header is available as accessory part.
See page 22 in this manual for details on the low-loss header.

The 3-way mixing valve, built-in to achieve the low temperature level of the underfloor heating circuit, is controlled by an accessory kit for a heating circuit with mixing valve. The circulation pump built into the Vitodens 200 boiler supplies the heating circuit up to the low-loss header. The radiator heating circuit is supplied by a circulation pump installed on site.

IMPORTANT

An expansion board (optional) must be ordered from Viessmann to control this pump. See page 22 for details.

The underfloor heating circuit is supplied by a circulation pump installed on site which is controlled by the accessory kit. Upon a call for DHW, the built-in diverting solenoid valve is energized. The boiler hot water is diverted to the DHW loop at maximum pump rotational speed (no variable speed pump operation during DHW production). Once the DHW tank is satisfied, the built-in diverting solenoid valve is de-energized and heating operation resumes.

IMPORTANT

DHW supply and return piping between boiler DHW connections and the Viessmann

DHW tank connections (S), shall be a minimum of 1" nominal pipe diameter (irrespective of the 3/4" DHW connection outlet sizes provided on the boiler and the DHW tank). This will ensure the residual head of the built-in pump is fully utilized to overcome the resistance of the DHW heat exchanger coil and to provide sufficient water flow to the boiler heat exchanger. In non-Viessmann DHW tank applications, perform, in addition to the above, accurate calculations for DHW tank coil pressure drop versus boiler pump residual head to ensure sufficient water flow to the boiler heat exchanger. Failure to heed the above instructions may cause boiler short-cycling and inadequate DHW supply.

System Layout 4

Vitodens 200 (up to model WB2 8-32) with...

- DHW storage tank
- two heating circuits with a mixing valve

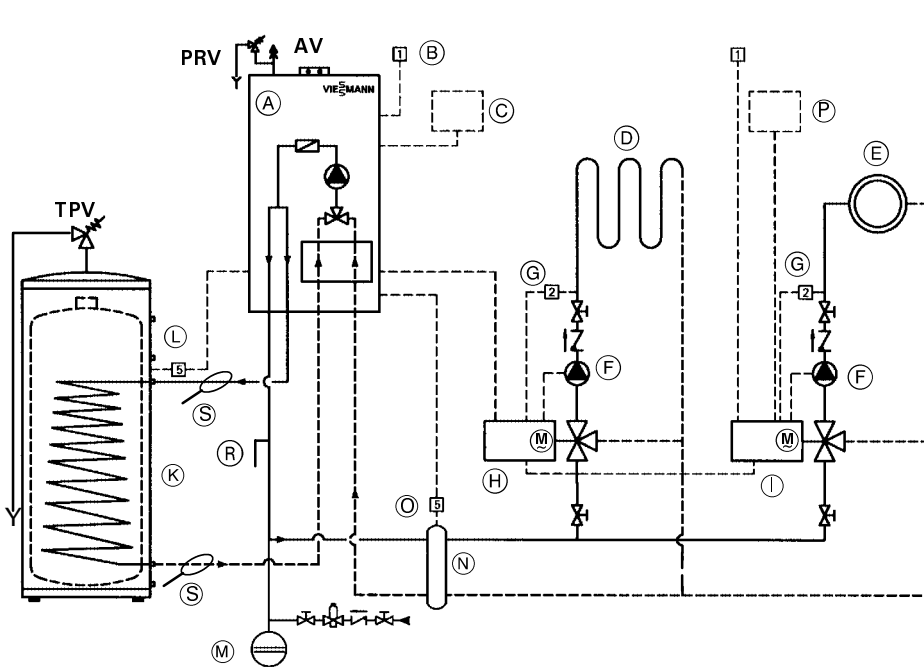

Important:
Please note location of expansion tank

- AV Air vent
- PRV Pressure relief valve
- TPV Temperature and pressure relief valve
- (A) Vitodens 200 gas-fired condensing boiler with programming unit for weather-responsive operation with 2-wire BUS expansion module
- (B) Outdoor temperature sensor [1]
- (C) Remote control for programming unit
- (D) Underfloor heating circuit
- (E) Radiator heating circuit
- (F) Heating circuit pump (field supplied)
- (G) Mixing valve temperature sensor [2]
- (H) Accessory kit for a heating circuit with mixing valve
- (I) Vitotronic 050/Dekamatik-HK1 control with communication module
- (K) DHW storage tank
- (L) DHW tank temperature sensor [5]
- (M) Expansion tank
- (N) Low-loss header
- (O) Viessmann temperature sensor for low-loss header [5]
- (P) Vitotrol 200 remote control
- (R) Optional purge tee (field supplied) for easier air removal
- (S) DHW supply and return piping

Installation of different heating circuits...

- radiator heating circuit
- underfloor heating circuit with 3-way mixing valve (low temperature circuit)
- DHW production

...with the following flow conditions

1. The total flow rate of the two heating circuits is **greater** than the maximum possible flow rate of the Vitodens 200 (see following table).

Model No.	Max. flow rate (GPM/ltr/h)
Vitodens 200,	
WB2 6-24C	6.2/1400
WB2 6-24	6.2/1400
WB2 8-32	7.0/1600

The use of a low-loss header is therefore recommended. The low-loss header is available as accessory part. See page 22 in this manual for details on the low-loss header.

The 3-way mixing valve, built-in to achieve the low temperature level of the underfloor heating circuit, is controlled by an accessory kit for a heating circuit with mixing valve.

The circulation pump built into the Vitodens 200 boiler supplies the heating circuit up to the low-loss header.

The underfloor and radiator heating circuits are supplied by circulation pumps installed on site which are controlled by the accessory kit or the Vitotronic 050/Dekamatik-HK1 control.

If more than two heating circuits with mixing valves are to be connected, they can be controlled by the Vitocontrol. Contact your local Viessmann Technical Sales Representative for details.

Upon a call for DHW, the built-in diverting solenoid valve is energized. The boiler hot water is diverted to the DHW loop at maximum pump rotational speed (no variable speed pump operation during DHW production). Once the DHW tank is satisfied, the built-in diverting solenoid valve is de-energized and heating operation resumes.

IMPORTANT

DHW supply and return piping between boiler DHW connections and the Viessmann

DHW tank connections (S), shall be a minimum of 1" nominal pipe diameter (irrespective of the 3/4" DHW connection outlet sizes provided on the boiler and the DHW tank). This will ensure the residual head of the built-in pump is fully utilized to overcome the resistance of the DHW heat exchanger coil and to provide sufficient water flow to the boiler heat exchanger. In non-Viessmann DHW tank applications, perform, in addition to the above, accurate calculations for DHW tank coil pressure drop versus boiler pump residual head to ensure sufficient water flow to the boiler heat exchanger. Failure to heed the above instructions may cause boiler short-cycling and inadequate DHW supply.

Installation Examples

System Layout 5

Vitodens 200 (up to model WB2 8-32) with...

- direct-connected heating circuit
- one heating circuit with system separation

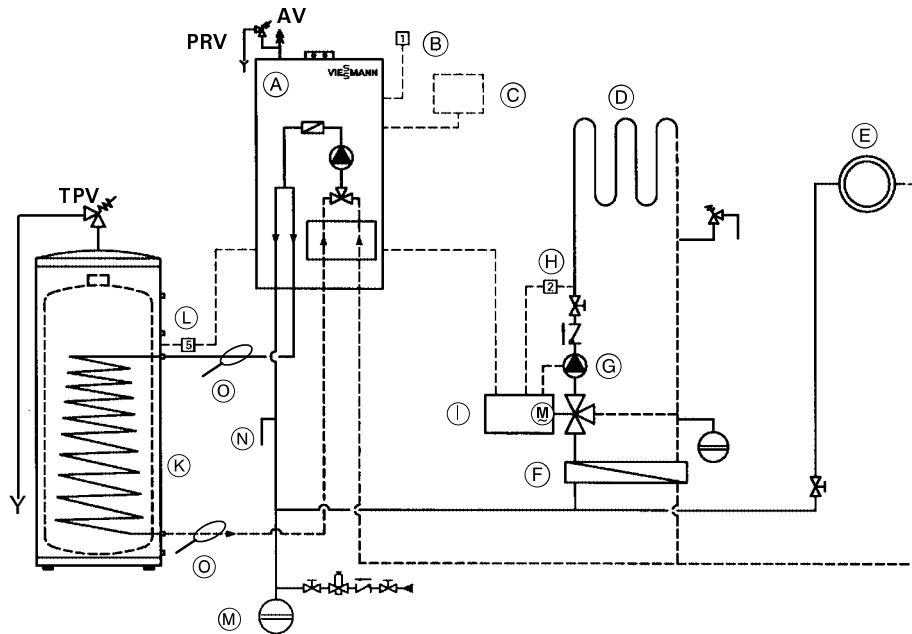

Important:
Please note location of expansion tank

AV Air vent
PRV Pressure relief valve
TPV Temperature and pressure relief valve

- (A) Vitodens 200 gas-fired condensing boiler with programming unit for weather-responsive operation
- (B) Outdoor temperature sensor [1]
- (C) Remote control for programming unit
- (D) Underfloor heating circuit
- (E) Radiator heating circuit
- (F) Plate heat exchanger for system separation
- (G) Heating circuit pump (field supplied)
- (H) Mixing valve temperature sensor [2]
- (I) Accessory kit for heating circuit with mixing valve
- (K) DHW storage tank
- (L) DHW tank temperature sensor [5]
- (M) Expansion tank
- (N) Optional purge tee (field supplied) for easier removal of air
- (O) DHW supply and return piping

Installation of different heating circuits...

- radiator heating circuit (high temperature circuit)
- underfloor heating circuit with 3-way mixing valve (low temperature circuit)
- DHW production

...with the following flow conditions

1. The flow rate (output) of the radiator heating circuit is at least 30% greater than that of the underfloor heating circuit.
2. The total flow rate of the two heating circuits is less than the maximum possible water flow rate of the Vitodens 200 boiler (see following table).

Model No.	Max. flow rate (GPM/ltr/h)
Vitodens 200,	
WB2 6-24C	6.2/1400
WB2 6-24	6.2/1400
WB2 8-32	7.0/1600

The use of a low-loss header is strongly recommended if the maximum water flow rate in the application concerned exceeds the values shown in the preceding table, or if the system flow rates are unknown. The low-loss header is available as an accessory part.

See preceding pages for installation examples with a low-loss header.

See page 22 in this manual for details on the low-loss header.

The 3-way mixing valve, built-in to achieve the low temperature level of the underfloor heating circuit, is controlled by an accessory kit for a heating circuit with mixing valve. The circulation pump built into the Vitodens 200 boiler supplies the radiator heating circuit and the plate heat exchanger for system separation. The underfloor heating circuit is supplied by a circulation pump installed on site which is controlled by the accessory kit.

Upon a call for DHW, the built-in diverting solenoid valve is energized. The boiler hot water is diverted to the DHW loop at maximum pump rotational speed (no variable speed pump operation during DHW production). Once the DHW tank is satisfied, the built-in diverting solenoid valve is de-energized and heating operation resumes.

IMPORTANT

The pressure drop (secondary circuit) of the plate heat exchanger (F) must be less than/equal to (\leq) the pressure drop of the 3-way mixing valve. This must be taken into account when sizing the plate heat exchanger.

IMPORTANT

DHW supply and return piping between boiler DHW connections and the Viessmann DHW tank connections (O), shall be a minimum of 1" nominal pipe diameter (irrespective of the 3/4" DHW connection outlet sizes provided on the boiler and the DHW tank). This will ensure the residual head of the built-in pump is fully utilized to overcome the resistance of the DHW heat exchanger coil and to provide sufficient water flow to the boiler heat exchanger. In non-Viessmann DHW tank applications, perform, in addition to the above, accurate calculations for DHW tank coil pressure drop versus boiler pump residual head to ensure sufficient water flow to the boiler heat exchanger. Failure to heed the above instructions may cause boiler short-cycling and inadequate DHW supply.

System Layout 6

Vitodens 200 (model WB2 11-44 and up) with...

- DHW storage tank and
- one direct-connected heating circuit

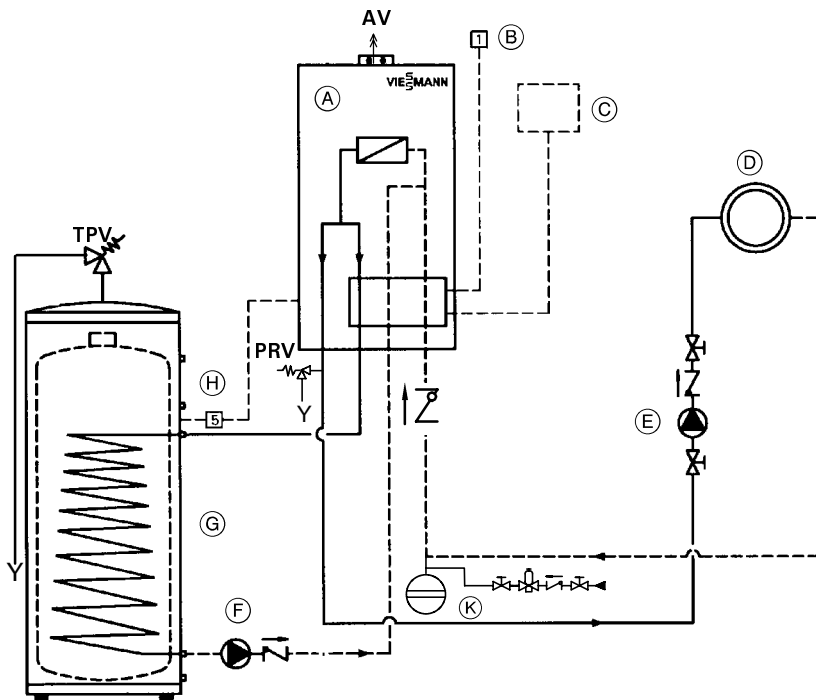

- AV Air vent
- PRV Pressure relief valve
- TPV Temperature and pressure relief valve
- (A) Vitodens 200 gas-fired condensing boiler with programming unit for weather-responsive operation
- (B) Outdoor temperature sensor of control unit for weather-responsive operation ¹
- (C) Remote control for programming unit
- (D) Heating circuit
- (E) Heating circuit pump (field supplied)
- (F) DHW circulating pump (field supplied)
- (G) DHW storage tank
- (H) DHW tank temperature sensor ⁵
- (K) Expansion tank

Please note!

The use of a low-loss header is recommended if the system water flow rate is **less** than 1.3 GPM / 300 ltr/h or **more** than 15.4 GPM / 3500 ltr/h.

The low-loss header is available as accessory part.

See page 22 in this manual for details on the low-loss header.

Model No.	Max. flow rate (GPM/ltr/h)
Vitodens 200,	
WB2 11-44	15.4/3500
WB2 15-60	15.4/3500

IMPORTANT

DHW circulating pump (F) must pump *into* the Vitodens 200 boiler (as illustrated).

Installation Examples

System Layout 7

Vitodens 200 (model WB2 11-44 and up) with...

- DHW storage tank
- one heating circuit with mixing valve and system separation

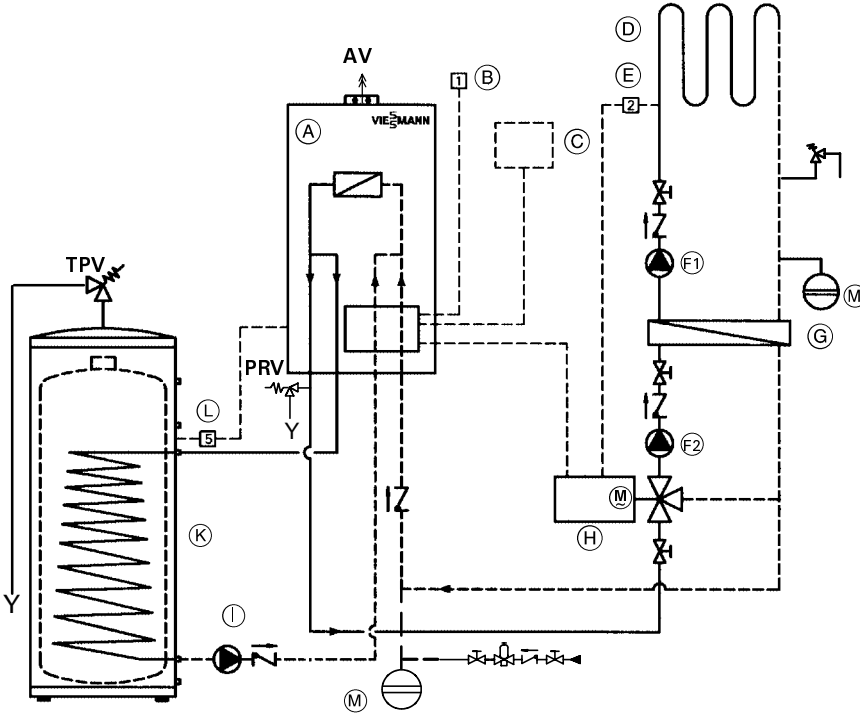

AV Air vent
 PRV Pressure relief valve
 TPV Temperature and pressure relief valve

- (A) Vitodens 200 gas-fired condensing boiler with programming unit for weather-responsive operation
- (B) Outdoor temperature sensor of control unit for weather-responsive operation ¹
- (C) Remote control
- (D) Underfloor heating circuit
- (E) Mixing valve temperature sensor ²
- (F1) Heating circuit pump (field supplied)
- (F2) Heating circuit pump (field supplied), located upstream of heat exchanger (see Important below)
- (G) Plate heat exchanger for system separation
- (H) Accessory kit for heating circuit with mixing valve
- (I) DHW circulating pump (field supplied)
- (K) DHW storage tank
- (L) DHW tank temperature sensor ⁵
- (M) Expansion tank

Please note!

The use of a low-loss header is recommended if the system water flow rate is **less** than 1.3 GPM / 300 ltr/h or **more** than 15.4 GPM / 3500 ltr/h.

The low-loss header is available as accessory part.

See page 22 in this manual for details on the low-loss header.

Please note!

System separation is required of underfloor heating systems employing non-oxygen diffusion barrier tubing.

All components on the secondary side of the heat exchanger must be made of corrosion-resistant materials.

IMPORTANT

DHW circulation pump (I) must pump *into* the Vitodens 200 boiler (as illustrated).

IMPORTANT

Sizing of field-supplied pump (F2) is critical to the proper boiler operation in system layout 7 (above). The selected pump performance curve must be at least equivalent to those shown on page 10 of this manual, or better.

An undersized pump may cause short-cycling and/or improper operation of the boiler. Viessmann **STRONGLY** recommends using a low-loss header and a boiler pump in system layout 7 (above).

Model No.	Max. flow rate (GPM/ltr/h)
Vitodens 200,	
WB2 11-44	15.4/3500
WB2 15-60	15.4/3500

System Layout 8

Vitodens 200 (model WB2 11-44 and up) with...

- DHW storage tank
- low-loss header
- one heating circuit with mixing valve

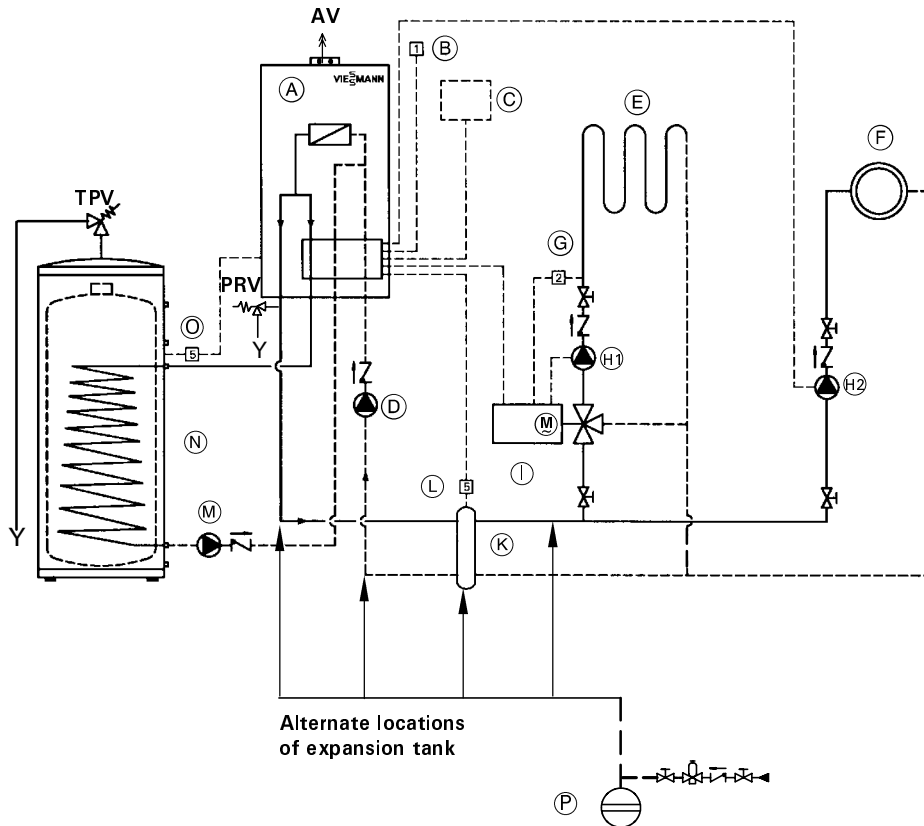

- AV Air vent
- PRV Pressure relief valve
- TPV Temperature and pressure relief valve
- (A) Vitodens 200 gas-fired condensing boiler with programming unit for weather-responsive operation
- (B) Outdoor temperature sensor of control unit for weather-responsive operation 1
- (C) Remote control
- (D) Primary pump (boiler circuit, field supplied) *with low-loss header only*
- (E) Underfloor heating circuit
- (F) Radiator heating circuit
- (G) Mixing valve temperature sensor 2
- (H1) Heating circuit pump (field supplied)
- (H2) Heating circuit pump (field supplied)
- (I) Accessory kit for heating circuit with mixing valve
- (K) Low-loss header
- (L) Viessmann temperature sensor for low-loss header 5
- (M) DHW circulating pump (field supplied)
- (N) DHW storage tank
- (O) DHW tank temperature sensor 5
- (P) Expansion tank

Please note!

The use of a low-loss header is recommended if the water flow rate is **less** than 1.3 GPM / 300 ltr/h or **more** than 15.4 GPM / 3500 ltr/h.

The low-loss header is available as accessory part.

See page 22 in this manual for details on the low-loss header.

The radiator heating circuit is supplied by a circulation pump (field supplied). An expansion board (optional) must be ordered from Viessmann to control this pump.

The underfloor heating circuit is supplied by a circulation pump installed on site which is controlled by the accessory kit.

The DHW circulation pump is field supplied.

IMPORTANT

Pumps (D) and (M) must pump into the Vitodens 200 boiler (as illustrated).

Model No.	Max. flow rate (GPM/ltr/h)
Vitodens 200,	
WB2 11-44	15.4/3500
WB2 15-60	15.4/3500

Installation Examples

System Layout 9

Vitodens 200 (model WB2 11-44 and up) with...

- DHW storage tank
- two heating circuits with a mixing valve

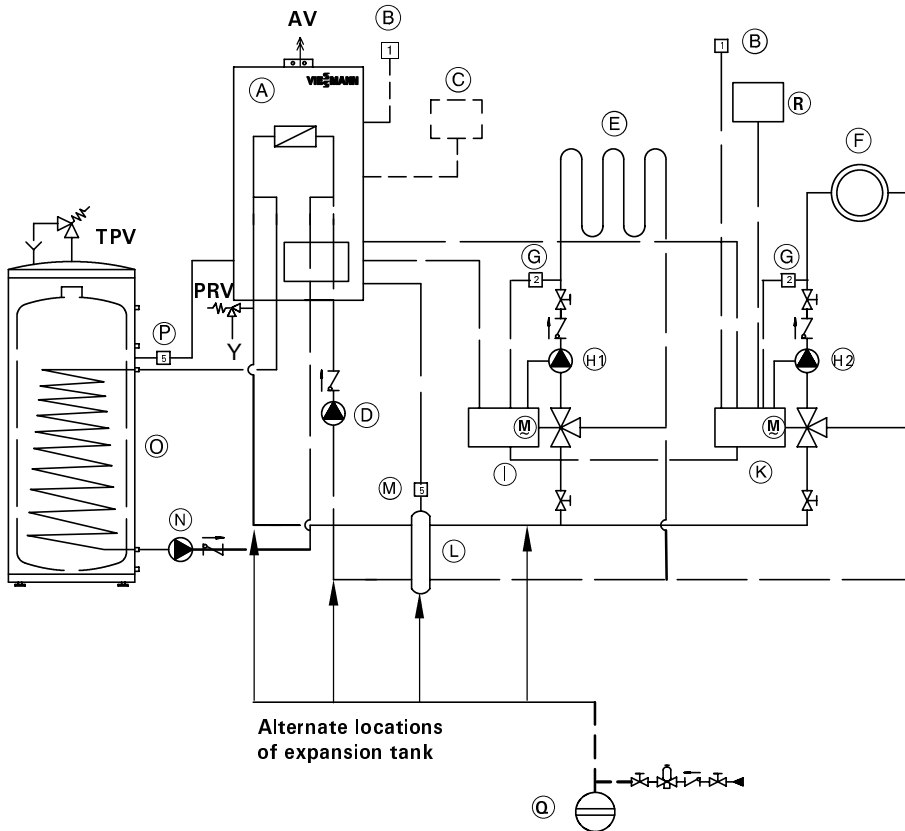

AV Air vent
 PRV Pressure relief valve
 TPV Temperature and pressure relief valve

- (A) Vitodens 200 gas-fired condensing boiler with programming unit for weather-responsive operation with 2-wire BUS expansion module
- (B) Outdoor temperature sensor [1]
- (C) Remote control for programming unit
- (D) Primary pump (boiler circuit, field supplied) *with low-loss header only*
- (E) Underfloor heating circuit
- (F) Radiator heating circuit
- (G) Mixing valve temperature sensor [2]
- (H1) Heating circuit pump (field supplied)
- (H2) Heating circuit pump (field supplied)
- (I) Accessory kit for heating circuit with mixing valve
- (K) Vitotronic 050/Dekamatik-HK1 control with communication module
- (L) Low-loss header
- (M) Viessmann temperature sensor for low-loss header [5]
- (N) DHW circulating pump (field supplied)
- (O) DHW storage tank
- (P) DHW tank temperature sensor [5]
- (Q) Expansion tank
- (R) Vitotrol 200 remote control

Installation of different heating circuits...

- radiator heating circuit
- underfloor heating circuit with 3-way mixing valve (low temperature circuit)
- DHW production

...with the following flow conditions

1. The total flow rate of the two heating circuits is **greater** than the maximum possible flow rate of the Vitodens 200 (see following table).

Model No.	Max. flow rate (GPM/ltr/h)
Vitodens 200,	
WB2 11-44	15.4/3500
WB2 15-60	15.4/3500

The use of a low-loss header is therefore recommended.
 The low-loss header is available as accessory part.
 See page 22 in this manual for details on the low-loss header.

The 3-way mixing valve, built-in to achieve the low temperature level of the underfloor heating circuit, is controlled by an accessory kit for a heating circuit with mixing valve.

The underfloor and radiator heating circuits are supplied by circulation pumps installed on site which are controlled by the accessory kit or the Vitotronic 050/Dekamatik-HK1 control.

If more than two heating circuits with mixing valves are to be connected, they can be controlled by the Vitocontrol.

Contact your local Viessmann Technical Sales Representative for details.

The DHW circulating pump is field supplied.

System Layout 10

- Vitodens 200 (model WB2 11-44 and up) with...
- DHW storage tank
 - low-loss header
 - multiple heating circuits with a mixing valve

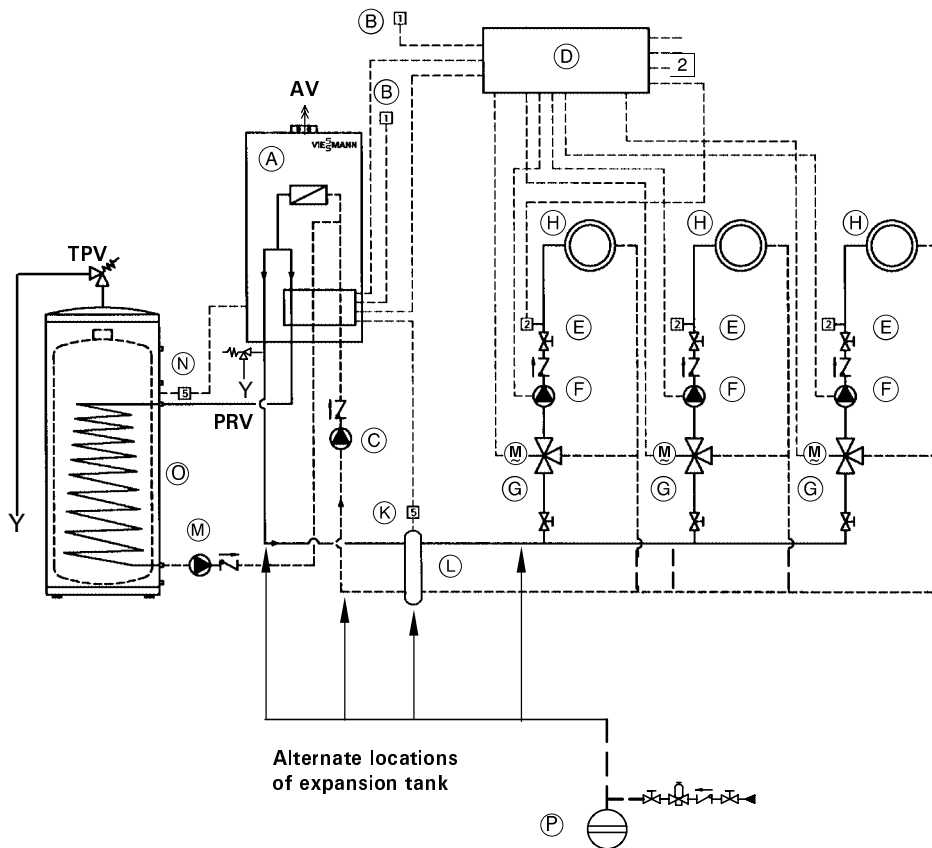

- AV Air vent
 PRV Pressure relief valve
 TPV Temperature and pressure relief valve
- (A) Vitodens 200 gas-fired condensing boiler with programming unit for weather-responsive operation and Viessmann 2-wire BUS expansion module
 - (B) Outdoor temperature sensor of control unit for weather-responsive operation 1
 - (C) Primary pump (boiler circuit, field supplied) *with low-loss header only*
 - (D) Vitocontrol ^{*1}
 - (E) Mixing valve temperature sensor 2
 - (F) Heating circuit pump (field supplied)
 - (G) Accessory kit for heating circuit with mixing valve
 - (H) Heating circuit with mixing valve
 - (K) Viessmann temperature sensor for low-loss header 5
 - (L) Low-loss header
 - (M) DHW circulating pump (field supplied)
 - (N) DHW tank temperature sensor 5
 - (O) DHW storage tank
 - (P) Expansion tank

**1Contact your local Sales Representative for details.*

IMPORTANT

Pumps (C) and (M) must pump *into* the Vitodens 200 boiler (as illustrated).

When designing a system as illustrated above, please contact your local Viessmann Sales Representative for assistance.

Installation Examples

Installation Example

Multiple Vitodens 200, WB2-44 or -60 installation (up to four boilers) with one boiler dedicated to DHW production and one heating circuit.

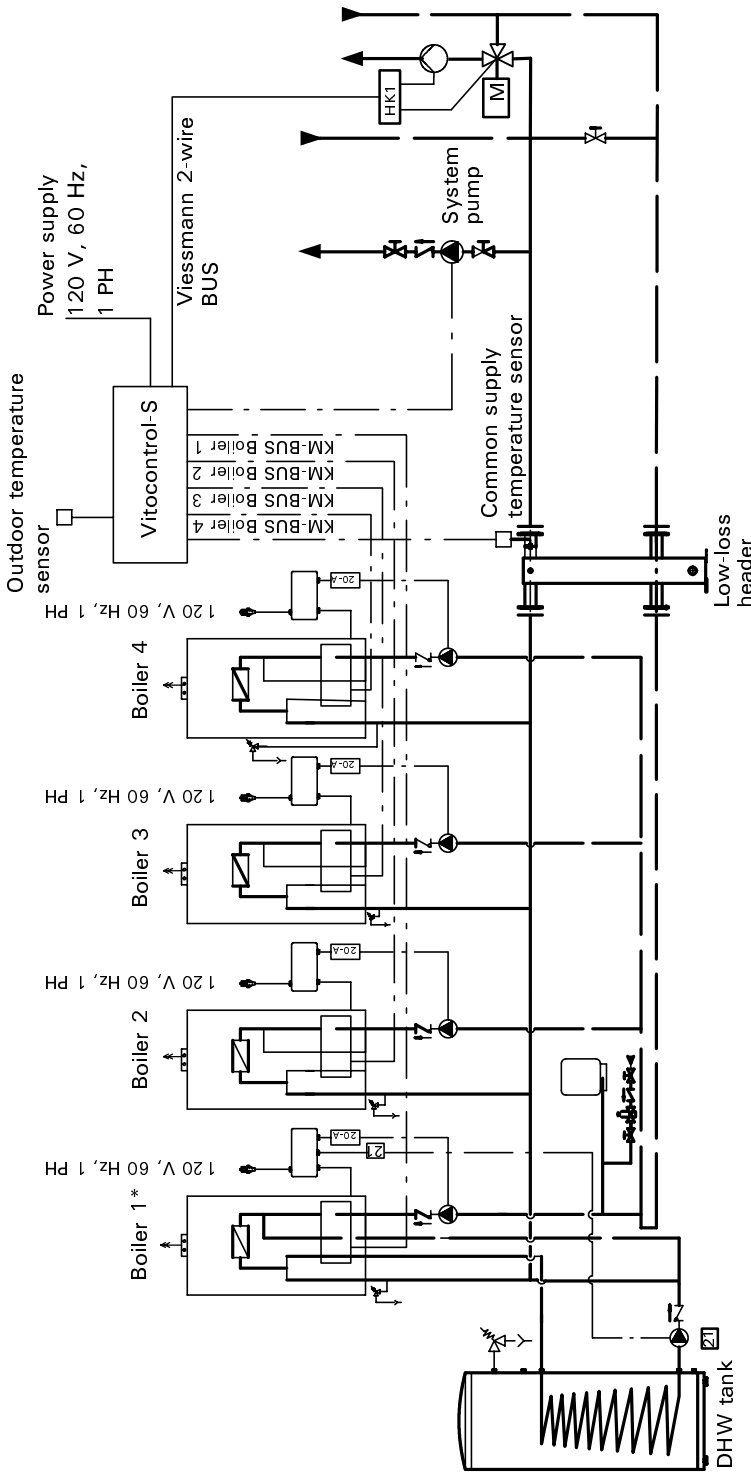

IMPORTANT

This installation example depicts a possible piping layout for multiple Vitodens 200 boilers equipped with Viessmann System Technology. Please note that this example is based on a simplified conceptual drawing only! Piping and necessary componentry must be field verified.

A low water cut-off (LWCO) must be installed where required by local codes. Proper installation and functionality in the field is the responsibility of the heating contractor.

WARNING

If a DHW storage tank other than a Viessmann Vitocell 100 or 300 tank is used, the installer must verify proper operation of the Viessmann DHW tank temperature sensor with the original manufacturer of the tank. Viessmann strongly recommends the installation of a temperature tempering valve in the DHW supply line.

* A DHW recirculation pump (#20) can be connected to Boiler 1 only.

In a Vitocontrol-S application, ALL boiler pumps must be connected to connector #20-A in the power pump module.

System Design Considerations

IN THE COMMONWEALTH OF MASSACHUSETTS...

-this product shall be installed by a licensed plumber or gas fitter.

-the flexible connector (if used) cannot exceed 36".

-any level type shutoff used must be of tee handle type.

Boiler location

As a direct vent appliance, the Vitodens 200 can be installed for room air independent operation (sealed combustion) **regardless** of size and ventilation method of the room in which it is located.

The Vitodens 200 can be installed, for example, in the main living area of a house, in non-ventilated utility rooms, cupboards, closets and alcoves with no clearance required from combustible materials, as well as in attics with a direct outlet for the flue gas/fresh air system. Follow all local and national codes.

Flue gas system

Viessmann PPS (Polypropylene) concentric flue gas/fresh air systems for room air independent operation (sealed combustion) and side wall venting are tested to ANSI Z21.13 - CSA 4.9 - 2000 standards and are certified together with the Vitodens 200 boiler as a constructional unit.

The Vitodens 200 boiler may also be vented vertically, using an AL29-4C® special stainless steel, single-wall, room air dependent venting system (UL listed for category IV).

For a more detailed description of the direct vent and single-wall vent system, please refer to the Vitodens 200 Venting System Installation Instructions.

Flue gas temperature protection

Flue pipes used for the Vitodens 200 are suitable for max. flue gas temperatures of up to 248 °F/120 °C.

No flue gas temperature protection is required as the maximum permissible flue gas temperature is not exceeded in any operating condition or in the event of malfunctioning.

Low water cut-off

A low water cut-off may be required by local codes. If the boiler is installed above the radiation level, a low water cut-off device of approved type must be installed in all instances. An approved type low water cut-off device must be provided by the heating contractor. Do not install an isolation valve between the boiler and the low water cut-off.

System layout

- The max. boiler water temperature for ...
 - space heating is 167 °F/75 °C.
 - DHW production is 172 °F/78 °C.
 To minimize distribution losses, Viessmann recommends that the heating and domestic hot water systems be based on a maximum boiler supply temperature of 158 °F/70 °C.
- Due to the low return temperatures required for gas condensing, no mixing valves should be used in the heating circuit whenever possible. If mixing valves are required, e.g. for multi-circuit systems or underfloor heating systems, only 3-way mixing valves must be used.

Do not use 4-way mixing valves with condensing boilers.

Water connections

Vitodens 200 boilers can be used in any fully pumped hot water heating system. Minimum system pressure is 0.8 bar/12 psig.

Chemical corrosion protection products

Corrosion does not typically occur in sealed heating systems which have been correctly installed and are correctly operated. Many manufacturers of plastic pipes recommend the use of chemical additives. In this case, only those commercially available corrosion protection products approved for boilers with domestic hot water heating via single-wall heat exchangers (instantaneous plate heat exchangers or DHW tanks) must be used.

Underfloor heating systems

For underfloor heating systems Viessmann recommends the use of plastic tubing with an oxygen diffusion barrier in order to prevent the diffusion of oxygen through tubing. If plastic tubing without an oxygen diffusion barrier is used in underfloor heating systems, Viessmann recommends that such systems be separated from the boiler with a heat exchanger.

Underfloor heating systems and heating circuits containing a very large volume of water must be connected to the boiler via a 3-way mixing valve; please refer to the applicable installation example in this manual.

Oxygen diffusion barrier underfloor tubing

The boiler warranty does not cover leaks resulting from corrosion caused by the use of underfloor plastic tubing without an oxygen diffusion barrier. Such systems must have the non-oxygen diffusion barrier tubing separated from the boiler with a heat exchanger. Viessmann recommends the use of underfloor plastic tubing with an oxygen diffusion barrier.

Water quality

Treatment for boiler feed water should be considered in areas of known problems, such as where a high mineral content and hardness exist. In areas where freezing might occur, an antifreeze may be added to the system water to protect the system. Please adhere to the specifications given by the antifreeze manufacturer. Do not use automotive silicate based antifreeze. Please observe that an antifreeze/water mixture may require a backflow preventer within the automatic water feed and influence components such as diaphragm expansion tanks, radiation, etc. Maximum antifreeze content is 50% for the Vitodens 200 boiler. Do **not** use antifreeze other than specifically made for hot water heating systems. System also may contain components which might be negatively affected by antifreeze. Check total system frequently when filled with antifreeze. Advise system operator/ultimate owner that system is filled with a glycol mix. The heating contractor must provide a MSDS (Material Safety Data Sheet) for the antifreeze used to the system operator/ultimate owner.

Warranty

Our warranty does not cover damages resulting from the following:

- installation or service by unqualified and unlicensed personnel.
- attempting to perform any repair work on the boiler other than that mentioned in the boiler literature.
- tampering with or attempting, without Viessmann permission, to readjust the factory settings of the
 - combination gas valve
 - combustion air opening of the burner blower
- leaks resulting from corrosion caused by the use of underfloor plastic tubing without an oxygen diffusion barrier.

For detailed warranty information, please read warranty sheet supplied with product.

Appendix

Vitodens 200 Venting Alternatives

Venting Alternatives		Vent System Diameter						Type
		Viessmann Coaxial PPs Vent ¹		Stainless Steel Vent ²		CPVC Vent ³		
Max. Equivalent Length (EqL)		5"/125mm	6"/150mm	3"	4"	3"	4"	Diameter
Horizontally Vented								
WB2 6-24 (C)	EqL	20 / 6	26 / 8	52 / 16	63 / 19.2	52 / 16	63 / 19.2	ft / m
WB2 8-32	EqL	20 / 6	26 / 8	40 / 12	50 / 15.2	40 / 12	50 / 15.2	ft / m
WB2 11-44	EqL	—	20 / 6	—	52 / 16	—	52 / 16	ft / m
WB2 15-60	EqL	—	20 / 6	—	40 / 12	—	40 / 12	ft / m
	See Page(s)	34		36		38		Page
Vertically Vented								
WB2 6-24 (C)	EqL	33 / 10	39 / 12	66 / 20	79 / 24	66 / 20	79 / 24	ft / m
WB2 8-32	EqL	27 / 8	33 / 10	49 / 15	62 / 19	49 / 15	62 / 19	ft / m
WB2 11-44	EqL	—	33 / 10	—	66 / 20	—	66 / 20	ft / m
WB2 15-60	EqL	—	20 / 6	—	49 / 15	—	49 / 15	ft / m
	See Page(s)	35		37		39		Page
Horizontal Intake / Vertically Vented								
WB2 6-24 (C)	EqL	—	—	59 / 18	71 / 21.6	59 / 18	71 / 21.6	ft / m
WB2 8-32	EqL	—	—	44 / 13.5	57 / 17.1	44 / 13.5	57 / 17.1	ft / m
WB2 11-44	EqL	—	—	—	59 / 18	—	59 / 18	ft / m
WB2 15-60	EqL	—	—	—	44 / 13.5	—	44 / 13.5	ft / m
	See Page(s)			40		40		Page
		Select vent material based on vent configuration, preferred material, and necessary maximum equivalent length. Always follow Viessmann venting installation instructions. - Do not common vent Vitodens 200-W with any other appliance. - Layouts on the following pages are for illustrative purposes only .						

¹ Sealed combustion, coaxial vent material to be supplied by Viessmann **only**.

² Stainless steel vent material must be ULC/UL listed, stainless steel AL29-4C® for Category IV boilers.

Suggested sources: Flexmaster Canada Ltd. / Z-Flex (US) Inc., Heat-fab Division Selkirk Corp., ProTech Systems Inc., or Security Chimneys Int'l.

³ CPVC vent material must be ULC/UL listed, for Category IV boilers. Suggested source: IPEX Inc.

► Do **not** include first 87° elbow in equivalent vent length calculations (this applies to all vent materials).

Coaxial PPs Vent System

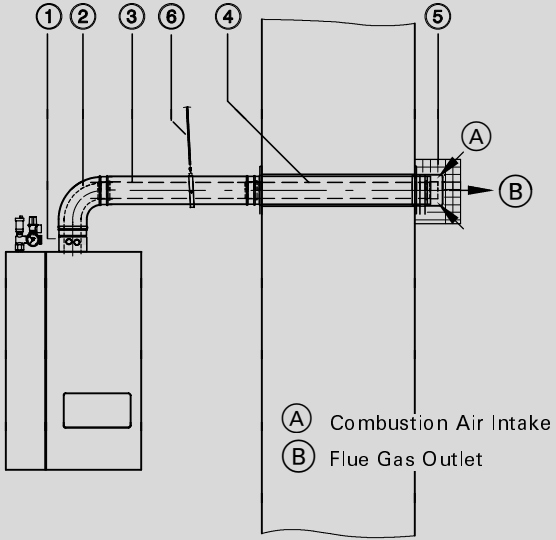
Vent System ¹	Vent System Diameter			Diameter		
		5"/125mm	6"/150mm		6"/150mm	
Horizontally Vented	Maximum Equivalent Length (EqL)	WB2 6-24(C) 20 / 6	6-24(C) 26 / 8	11-44 20 / 6	Model No. ft / m	
	Maximum Equivalent Length (EqL)	WB2 8-32 20 / 6	8-32 26 / 8	15-60 20 / 6	Model No. ft / m	
Room Air Independent Operation 	Basic Horizontal Vent Kit Venting pieces can be ordered individually, or as a convenient kit using the Order No. to the right; Basic Vent Kit includes one of each of the items numbered 1 to 5, and two Mounting Clips 6.	7134 408	7134 278		Order No.	
	1 Boiler Vent Adaptor (included with WB2 44/60)	7134 409	—	—	Order No.	
	Adaptor , coaxial 80/125 > 100/150 (not shown)	—	7142 680	—	Order No.	
	2 87° Elbow EqL = 1.6ft / 0.5m	7176 639	7176 674		Order No.	
	3 Straight Pipe ² 3.3ft / 1m	7176 637	7176 672		Order No.	
	4 Vent Termination 2.6ft / 0.8m	7246 527	7245 526		Order No.	
	5 Protective Screen ¹		7134 790		Order No.	
	6 Mounting Clip ² (each)	7176 664	7176 682		Order No.	
	Other Available Vent Pieces not shown in illustration above	87° Inspection Tee EqL = 1.6ft / 0.5m	7176 642	7176 677		Order No.
		Sliding Coupling 0.8ft / 0.25m	7176 663	7176 678		Order No.
Straight Pipe ² 1.6ft / 0.5m		7176 636	7176 671		Order No.	
45° Elbow (Set of 2) EqL = 1.0ft / 0.3m		7176 640	7176 675		Order No.	

¹ Sealed combustion, coaxial vent material to be supplied by Viessmann **only**.

Side wall venting installation **must** include Viessmann Protective Screen!

² Order **one** Mounting Clip for **each** straight length of vent pipe installed.

▶ Do **not** include first 87° elbow in equivalent vent length calculations (this applies to all vent materials).

▶ A **maximum** of **5** elbows may be installed in the vent system; do **not** exceed maximum equivalent vent length.

▶ Always follow Viessmann venting installation instructions.

5167 472 v3.4

Appendix (continued)

Coaxial PPs Vent System (continued)

Vent System ¹	Vent System Diameter			Diameter	
		5"/125mm	6"/150mm		6"/150mm
Vertically Vented	Maximum Equivalent Length (EqL)	WB2 6-24(C) 33 / 10	6-24(C) 39 / 12	11-44 33 / 10	Model No. ft / m
	Maximum Equivalent Length (EqL)	WB2 8-32 27 / 8	8-32 33 / 10	15-60 20 / 6	Model No. ft / m
Room Air Independent Operation	1 Boiler Vent Adaptor (included with WB2 44/60)		7134 409	—	Order No.
	Adaptor, coaxial 80/125 > 100/150 (not shown)		—	7142 680	Order No.
	2 87° Elbow EqL = 1.6ft / 0.5m	7176 639		7176 674	Order No.
	6 Mounting Clip ² (each)	7176 664		7176 682	Order No.
	7 87° Inspection Tee EqL = 1.6ft / 0.5m	7176 642		7176 677	Order No.
	8 Sliding Coupling 0.8ft / 0.25m	7176 663		7176 678	Order No.
	9 Straight Pipe ² 1.6ft / 0.5m	7176 636		7176 671	Order No.
	Straight Pipe ² 3.3ft / 1m	<i>or</i> 7176 637		<i>or</i> 7176 672	Order No.
	10 45° Elbow (Set of 2) EqL = 1ft / 0.3m	7176 640		7176 675	Order No.
	11 Vent Termination 3.9ft / 1.2m	7248 007		7339 762	Order No.
	12 Roof Flashing and Storm Collar (B-Vent material or better)			field supplied	Order No.

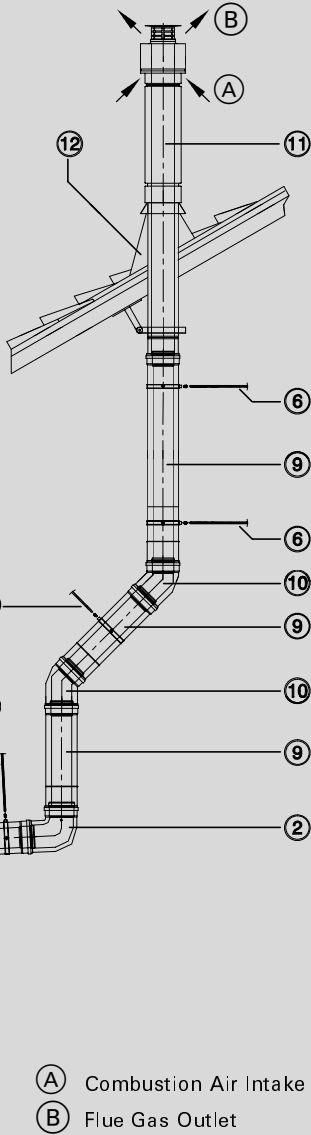

¹ Sealed combustion, coaxial vent material to be supplied by Viessmann **only**.

² Order **one** Mounting Clip for **each** straight length of vent pipe installed.

▶ Do **not** include first 87° elbow in equivalent vent length calculations (this applies to all vent materials).

▶ A **maximum** of **5 elbows** may be installed in the vent system; do **not** exceed maximum equivalent vent length.

▶ Always follow Viessmann venting installation instructions.

Stainless Steel Vent System

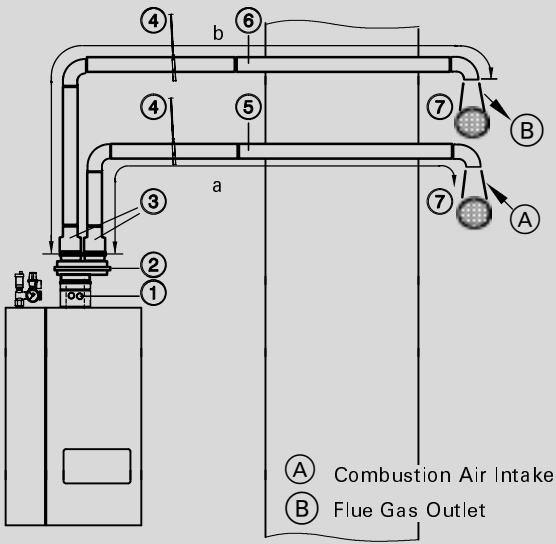
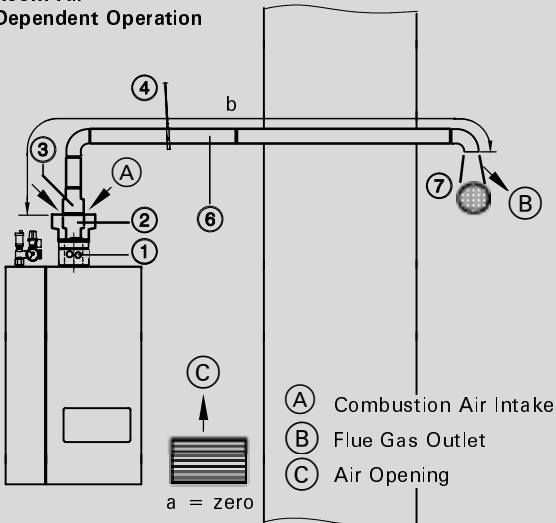
Vent System ¹	Vent System Diameter			Diameter	
	3"	4"	4"		
Horizontally Vented	Maximum Equivalent Length (EqL) WB2 a + b ≤	6-24(C) 52 / 16	6-24(C) 63 / 19.2	11-44 52 / 16	Model No. ft / m
	Maximum Equivalent Length (EqL) WB2 a + b ≤	8-32 40 / 12	8-32 50 / 15.2	15-60 40 / 12	Model No. ft / m
Room Air Independent Operation 	1 Boiler Vent Adaptor (included with WB2 44/60)	7134 409	—	—	Order No.
	2 Double-Pipe Adaptor	7189 822	7189 823	—	Order No.
	3 Adaptor(s) , stainless steel 80mm > 3" (order 2 pcs)	field supplied	field supplied	—	Order No.
	3" > 4" (order 2 pcs) (not shown)	—	field supplied	—	Order No.
	100mm > 4" (order 2 pcs)	—	—	field supplied	Order No.
	4 Venting Support ²	—	field supplied	—	Order No.
	5 Combustion Air Intake Vent Material Allowable materials: see note below ³	—	field supplied	—	Order No.
6 ULC/UL listed Stainless Steel Vent Material ¹ for EqL calculations, use: ■ 45° Elbow EqL = 2ft / 0.6m ■ 90° Elbow EqL = 3ft / 0.9m	—	field supplied	—	Order No.	
7 Bird Screen c/w Termination	—	field supplied	—	Order No.	
Room Air Dependent Operation 	1 Boiler Vent Adaptor (included with WB2 44/60)	7134 409	—	—	Order No.
	2 Adaptor , coaxial 80/125 > 100/150	—	7142 680	—	Order No.
	3 Adaptor , stainless steel 80mm > 3"	field supplied	—	—	Order No.
	100mm > 4"	—	field supplied	field supplied	Order No.
	4 Venting Support ²	—	field supplied	—	Order No.
	6 ULC/UL listed Stainless Steel Vent Material ¹ for EqL calculations, use: ■ 45° Elbow EqL = 2ft / 0.6m ■ 90° Elbow EqL = 3ft / 0.9m	—	field supplied	—	Order No.
	7 Bird Screen c/w Termination	—	field supplied	—	Order No.

¹ Stainless steel vent material must be ULC/UL listed, stainless steel AL29-4C® for Category IV boilers.
Suggested sources: Flexmaster Canada Ltd. / Z-Flex (US) Inc., Heat-fab Division Selkirk Corp., ProTech Systems Inc., or Security Chimneys Int'.
² Boiler cannot support weight of vent system. Support venting as prescribed in vent manufacturer's installation instructions.
³ Combustion air supply pipe may be made of the following materials: ABS, CPVC, PVC, or stainless steel.
▶ A maximum of 5 x 90° elbows may be installed in the air intake and flue outlet combined; do not exceed maximum equivalent vent length.
▶ Always follow Viessmann venting installation instructions.

5167 472 v3.4

Appendix (continued)

Stainless Steel Vent System (continued)

Vent System ¹	Vent System Diameter			Diameter		
	3"	4"	4"			
Vertically Vented	Maximum Equivalent Length (EqL) WB2 a + b ≤	6-24(C) 66 / 20	6-24(C) 79 / 24	11-44 66 / 20	Model No. ft / m	
	Maximum Equivalent Length (EqL) WB2 a + b ≤	8-32 49 / 15	8-32 62 / 19	15-60 49 / 15	Model No. ft / m	
Room Air Independent Operation	<p> A Combustion Air Intake B Flue Gas Outlet </p>	1 Boiler Vent Adaptor (included with WB2 44/60)	7134 409	—	Order No.	
		2 Double-Pipe Adaptor	7189 822	7189 823	Order No.	
		3 Adaptor(s), stainless steel 80mm > 3" (order 2 pcs)	field supplied	field supplied	—	Order No.
		3" > 4" (order 2 pcs) (not shown)	—	field supplied	—	Order No.
		100mm > 4" (order 2 pcs)	—	—	field supplied	Order No.
		4 Venting Support ²	field supplied		Order No.	
		5 Combustion Air Intake Vent Material Allowable materials: see note below ³	field supplied		Order No.	
Room Air Dependent Operation	<p> A Combustion Air Intake B Flue Gas Outlet C Air Opening a = zero </p>	1 Boiler Vent Adaptor (included with WB2 44/60)	7134 409	—	Order No.	
		2 Adaptor, coaxial 80/125 > 100/150	—	7142 680	—	Order No.
		3 Adaptor, stainless steel 80mm > 3"	field supplied	—	—	Order No.
		100mm > 4"	—	field supplied	field supplied	Order No.
		4 Venting Support ²	field supplied		Order No.	
		6 ULC/UL listed Stainless Steel Vent Material ¹ for EqL calculations, use: ■ 45° Elbow EqL = 2ft / 0.6m ■ 90° Elbow EqL = 3ft / 0.9m	field supplied		Order No.	
		7 Bird Screen c/w Termination	field supplied		Order No.	

¹ Stainless steel vent material must be ULC/UL listed, stainless steel AL29-4C® for Category IV boilers.
 Suggested sources: Flexmaster Canada Ltd. / Z-Flex (US) Inc., Heat-fab Division Selkirk Corp., ProTech Systems Inc., or Security Chimneys Int'l.
² Boiler cannot support weight of vent system. Support venting as prescribed in vent manufacturer's installation instructions.
³ Combustion air supply pipe may be made of the following materials: ABS, CPVC, PVC, or stainless steel.
 ▶ A maximum of 5 x 90° elbows may be installed in the air intake and flue outlet combined; do not exceed maximum equivalent vent length.

IMPORTANT :
Do not use any DWV plumbing pipes to vent this boiler.

CPVC Vent System

Vent System ¹	Vent System Diameter			Diameter	
	3"	4"	4"		
Horizontally Vented	Maximum Equivalent Length (EqL) WB2 a + b ≤	6-24(C) 52 / 16	6-24(C) 63 / 19.2	11-44 52 / 16	Model No. ft / m
	Maximum Equivalent Length (EqL) WB2 a + b ≤	8-32 40 / 12	8-32 50 / 15.2	15-60 40 / 12	Model No. ft / m
Room Air Independent Operation	1 Boiler Vent Adaptor (included with WB2 44/60)	7134 409	—	—	Order No.
	2 Double-Pipe Adaptor	7189 822	7189 823	—	Order No.
	3 Adaptor(s), CPVC 80mm > 3" (order 2 pcs) 3" > 4" (order 2 pcs) (not shown) 100mm > 4" (order 2 pcs)	7134 770	7134 770	—	Order No.
		—	and field supplied	—	Order No.
		—	—	7134 771	Order No.
	4 Venting Support ²	—	field supplied	—	Order No.
	5 Combustion Air Intake Vent Material Allowable materials: see note below ³	—	field supplied	—	Order No.
6 ULC/UL listed CPVC Vent Material ¹ for EqL calculations, use: ■ 45° Elbow EqL = 3ft / 0.9m ■ 90° Elbow EqL = 5ft / 1.5m	—	field supplied	—	Order No.	
7 Bird Screen (set of 2)	7134 781	7134 782	—	Order No.	
Room Air Dependent Operation	1 Boiler Vent Adaptor (included with WB2 44/60)	7134 409	—	—	Order No.
	2 Flue Adaptor, CPVC	7134 770	7134 771	—	Order No.
	3 Adaptor(s), CPVC 3" > 4"	—	field supplied	—	Order No.
	4 Venting Support ²	—	field supplied	—	Order No.
	6 ULC/UL listed CPVC Vent Material ¹ for EqL calculations, use: ■ 45° Elbow EqL = 3ft / 0.9m ■ 90° Elbow EqL = 5ft / 1.5m	—	field supplied	—	Order No.
	7 Bird Screen (set of 2)	7134 781	7134 782	—	Order No.

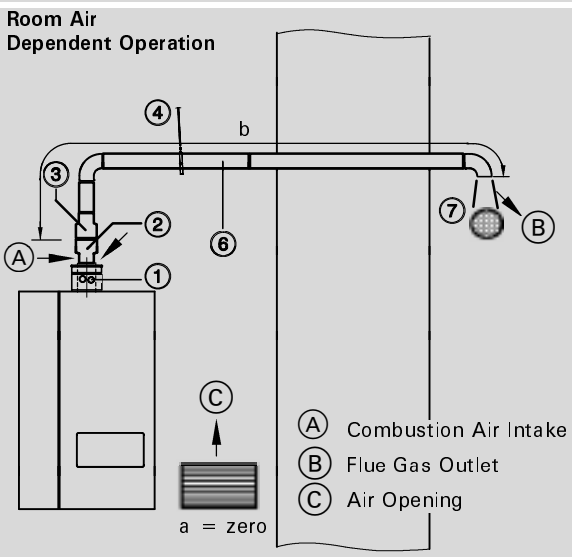
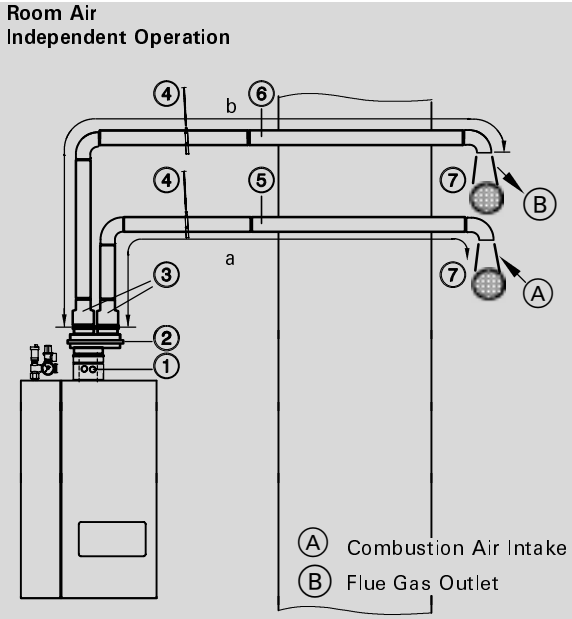

¹ CPVC vent material must be ULC/UL listed, for Category IV boilers. Suggested source: IPEX Inc.
² Boiler cannot support weight of vent system. Support venting as prescribed in vent manufacturer's installation instructions.
³ Combustion air supply pipe may be made of the following materials: ABS, CPVC, PVC, or stainless steel.
 ▶ Do not include first 87° elbow in equivalent vent length calculations (this applies to all vent materials).
 ▶ A maximum of 5 x 90° elbows may be installed in the air intake and flue outlet combined; do not exceed maximum equivalent vent length.
 ▶ Always follow Viessmann venting installation instructions.

5167 472 v3.4

IMPORTANT:
Do not use any DWV plumbing pipes to vent this boiler.

CPVC Vent System (continued)

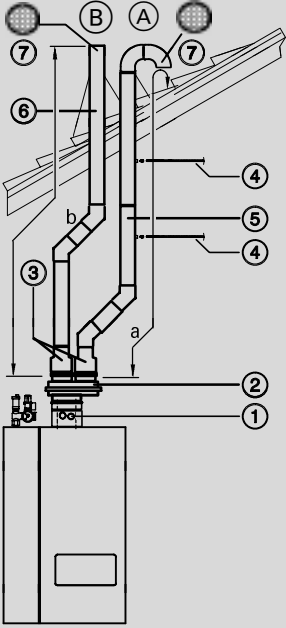
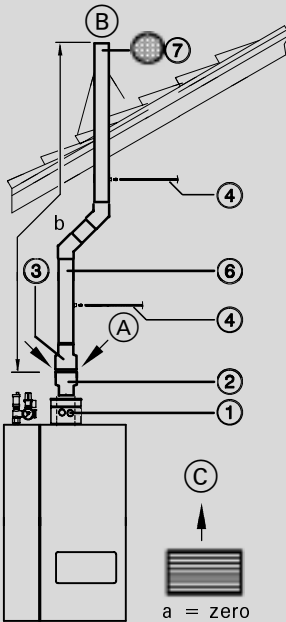
Vent System ¹	Vent System Diameter			Diameter		
	3"	4"	4"			
Vertically Vented	Maximum Equivalent Length (EqL) WB2 a + b ≤	6-24(C) 66 / 20	6-24(C) 79 / 24	11-44 66 / 20	Model No. ft / m	
	Maximum Equivalent Length (EqL) WB2 a + b ≤	8-32 49 / 15	8-32 62 / 19	15-60 49 / 15	Model No. ft / m	
Room Air Independent Operation	 <p> A Combustion Air Intake B Flue Gas Outlet </p>	1 Boiler Vent Adaptor (included with WB2 44/60)	7134 409	—	Order No.	
		2 Double-Pipe Adaptor	7189 822	7189 823	Order No.	
		3 Adaptor(s), CPVC 80mm > 3" (order 2 pcs)	7134 770	7134 770	—	Order No.
		3" > 4" (order 2 pcs) (not shown)	—	field supplied	—	Order No.
		100mm > 4" (order 2 pcs)	—	—	7134 771	Order No.
		4 Venting Support ²	field supplied		Order No.	
		5 Combustion Air Intake Vent Material Allowable materials: see note below ³	field supplied		Order No.	
Room Air Dependent Operation	 <p> A Combustion Air Intake B Flue Gas Outlet C Air Opening a = zero </p>	1 Boiler Vent Adaptor (included with WB2 44/60)	7134 409	—	Order No.	
		2 Flue Adaptor, CPVC	7134 770	7134 771	Order No.	
		3 Adaptor(s), CPVC 3" > 4"	—	field supplied	—	Order No.
		4 Venting Support ²	field supplied		Order No.	
		6 ULC/UL listed CPVC Vent Material ¹ for EqL calculations, use: ■ 45° Elbow EqL = 3ft / 0.9m ■ 90° Elbow EqL = 5ft / 1.5m	field supplied		Order No.	
		7 Bird Screen (set of 2)	7134 781	7134 782	Order No.	
		7 Bird Screen (set of 2)	7134 781	7134 782	Order No.	

¹ CPVC vent material must be ULC/UL listed, for Category IV boilers. Suggested source: IPEX Inc.

² Boiler cannot support weight of vent system. Support venting as prescribed in vent manufacturer's installation instructions.

³ Combustion air supply pipe may be made of the following materials: ABS, CPVC, PVC, or stainless steel.

▶ A maximum of 5 x 90° elbows may be installed in the air intake and flue outlet combined; do not exceed maximum equivalent vent length.

▶ Always follow Viessmann venting installation instructions.

IMPORTANT :
Do not use any DWV plumbing pipes to vent this boiler.

CPVC or Stainless Steel Vent System

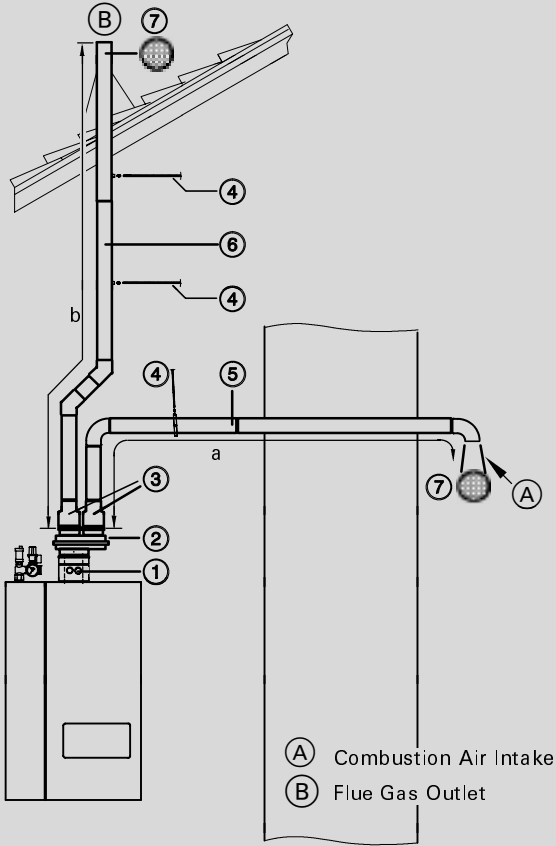
Vent System ¹	Vent System Diameter			Diameter	
		3"	4"		4"
Hybrid Vent System Horizontal Intake / Vertically Vented	Maximum Equivalent Length (EqL) WB2 a + b ≤	6-24(C) 59 / 18	6-24(C) 71 / 21.6	11-44 59 / 18	Model No. ft / m
	Maximum Equivalent Length (EqL) WB2 a + b ≤	8-32 44 / 13.5	8-32 57 / 17.1	15-60 44 / 13.5	Model No. ft / m
Room Air Independent Operation 	1 Boiler Vent Adaptor (Included with WB2 44/60)	7134 409		—	Order No.
	2 Double-Pipe Adaptor	7189 822		7189 823	Order No.
	3 Adaptor(s), stainless steel 80mm > 3" (order 2 pcs)	field supplied	field supplied	—	Order No.
	3" > 4" (order 2 pcs) (not shown)	—	field supplied	—	Order No.
	100mm > 4" (order 2 pcs) or	—	—	field supplied	Order No.
	3 Adaptor(s), CPVC 80mm > 3" (order 2 pcs)	7134 770	7134 770	—	Order No.
	3" > 4" (order 2 pcs) (not shown)	—	and field supplied	—	Order No.
	100mm > 4" (order 2 pcs)	—	—	7134 771	Order No.
	4 Venting Support ²	field supplied		—	Order No.
	5 Combustion Air Supply Pipe Allowable materials: see note below ³	field supplied		—	Order No.
6 ULC/UL listed Stainless Steel Vent Material ^{1a} for EqL calculations, use: ■ 45° Elbow EqL = 2ft / 0.6m ■ 90° Elbow EqL = 3ft / 0.9m or	field supplied		—	Order No.	
6 ULC/UL listed CPVC Vent Material ^{1b} for EqL calculations, use: ■ 45° Elbow EqL = 3ft / 0.9m ■ 90° Elbow EqL = 5ft / 1.5m	field supplied		—	Order No.	
7 Bird Screen c/w Termination for stainless steel or	field supplied		—	Order No.	
7 Bird Screen (set of 2) for CPVC	7134 781	7134 782	—	Order No.	

^{1a}Stainless steel vent material must be ULC/UL listed, stainless steel AL29-4C® for Category IV boilers.
Suggested sources: Flexmaster Canada Ltd. / Z-Flex (US) Inc., Heat-fab Division Selkirk Corp., ProTech Systems Inc., or Security Chimneys Int'.
^{1b}CPVC vent material must be ULC/UL listed, for Category IV boilers. Suggested source: IPEX Inc.
²Boiler cannot support weight of vent system. Support venting as prescribed in vent manufacturer's installation instructions.
³Combustion air supply pipe may be made of the following materials: ABS, CPVC, PVC, or stainless steel.
▶ Do not include first 87° elbow in equivalent vent length calculations (this applies to all vent materials).
▶ A maximum of 5 x 90° elbows may be installed in the air intake and flue outlet combined; do not exceed maximum equivalent vent length.
▶ Always follow Viessmann venting installation instructions.

Viessmann Manufacturing Company (U.S.) Inc.
45 Access Road
Warwick, Rhode Island • 02886 • USA
Tel. (401) 732-0667 • Fax (401) 732-0590
www.viessmann-us.com • info@viessmann-us.com

Viessmann Manufacturing Company Inc.
750 McMurray Road
Waterloo, Ontario • N2V 2G5 • Canada
Tel. (519) 885-6300 • Fax (519) 885-0887
www.viessmann.ca • info@viessmann.ca

